

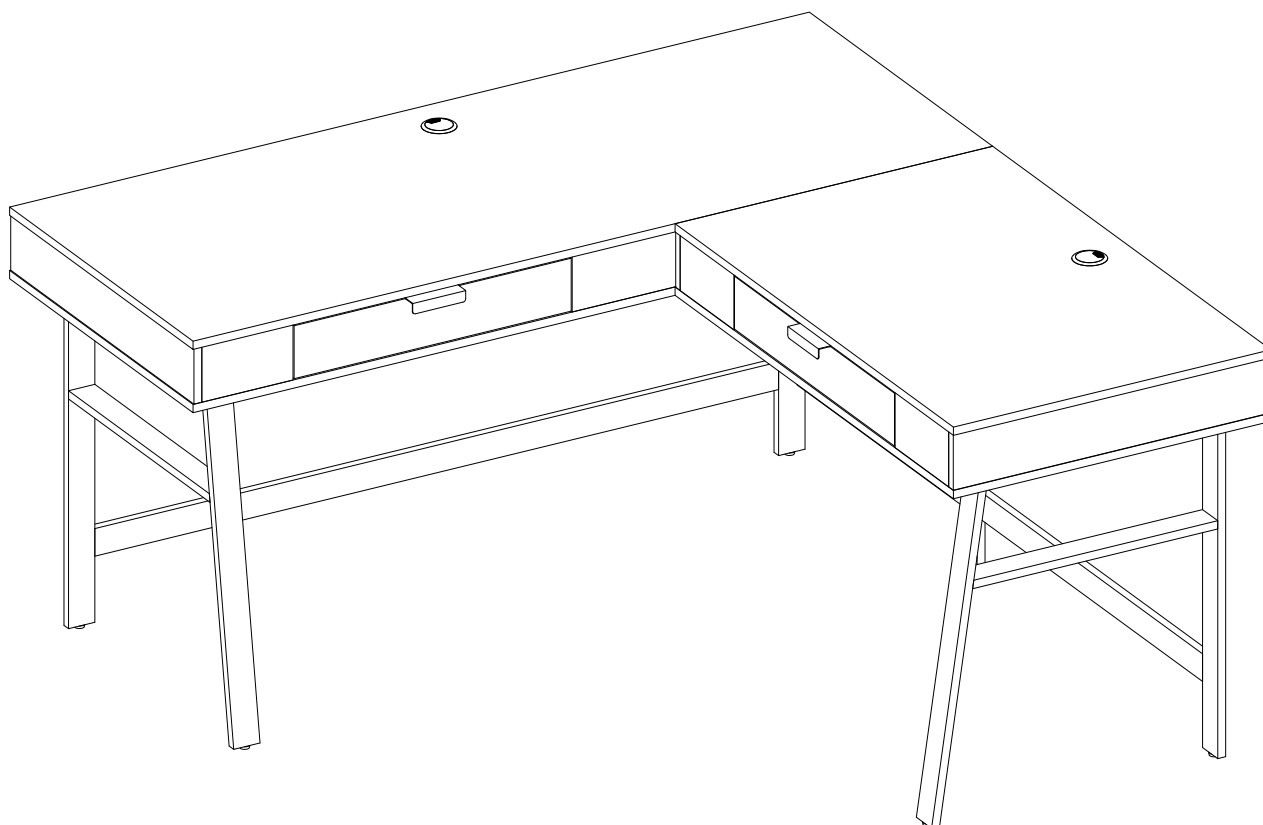

LOT NUMBER: _____
DATE PURCHASED: __/__/__

Timbercrest Desk Model # 19WTLD-SPCA



ADULT ASSEMBLY REQUIRED DUE TO THE PRESENCE OF SMALL PARTS, SHARP POINTS, SHARP EDGES AS RECEIVED

If you have any questions regarding assembly or if parts are missing, DO NOT return this item to the store where it was purchased. Please call our toll-free customer service number and have your instructions and parts list ready to provide the model name, part name or factory number:

1-866-942-5362

Pacific Standard Time: 8:30 a.m. - 4:30 p.m., Monday - Friday
Or visit our web site 24 hours a day, 7 days a week for product assistance at

www.whalenfurniture.com

Or e-mail your request to **parts@whalenfurniture.com**

**THIS INSTRUCTION BOOKLET CONTAINS IMPORTANT SAFETY INFORMATION.
PLEASE READ AND KEEP FOR FUTURE REFERENCE.**

Date 2019-10-25 Rev. 0001-A

MAXIMUM RECOMMENDED WEIGHT LOADS

MANUFACTURER: Whalen Furniture Manufacturing
CATALOG: Timbercrest Desk
MODEL #: 19WTLD-SPCA
MADE IN CHINA

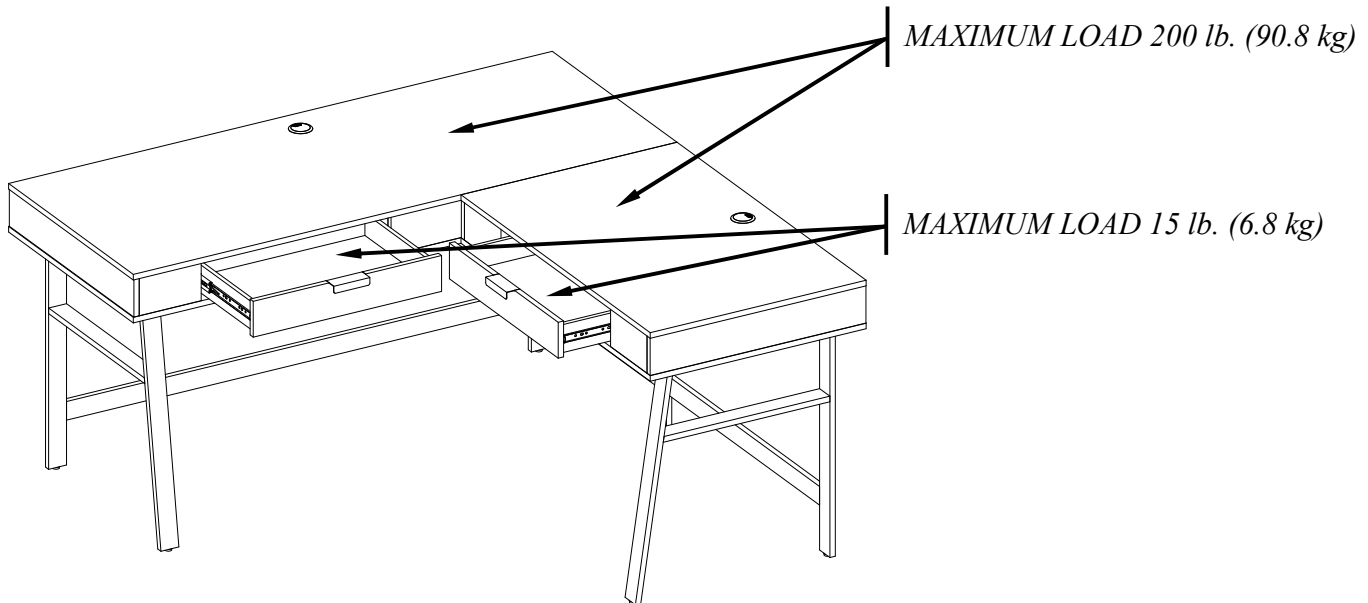

⚠ WARNING THIS UNIT IS INTENDED FOR USE ONLY WITH THE MAXIMUM WEIGHTS INDICATED. USE WITH LOAD HEAVIER THAN THE MAXIMUM WEIGHTS INDICATED MAY RESULT IN INSTABILITY, CAUSING POSSIBLE INJURY.

SPECIAL NOTE

Please read the instruction sheets completely before assembly. Examine all packaging material before discarding carton. Remove any remaining staples from the carton before discarding. Remove all parts from carton and separate into groups as indicated on part list. Please ensure all parts are included prior to assembly. Use of power tools to complete assembly is not recommended.

Parts and Hardware List

Please read completely through the instructions and verify that all listed parts and hardware are present before beginning assembly.

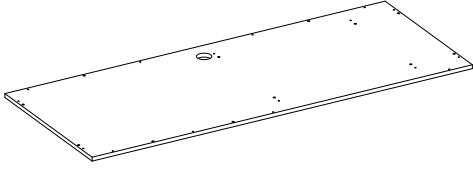

A- Desk Top Panel (Qty. 1)

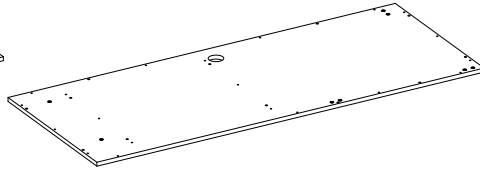

B- Desk Bottom Panel (Qty. 1)

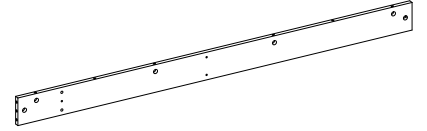

C- Desk Back Panel (Qty. 1)

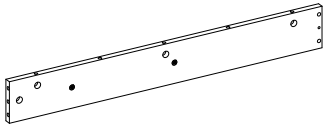

D- Desk Right Front Panel (Qty. 1)

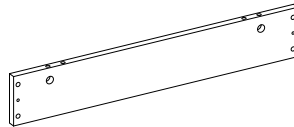

E- Desk Side Panel (Qty. 3)

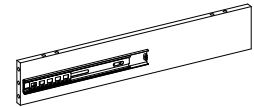

F- Left Partition Panel (Qty. 2)

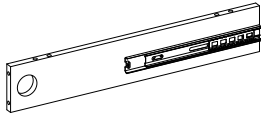

G- Desk Right Partition Panel (Qty. 1)

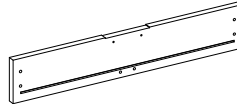

H1- Drawer Front (Qty. 2)

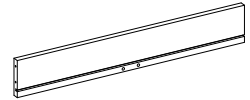

H2- Drawer Back Panel (Qty. 2)

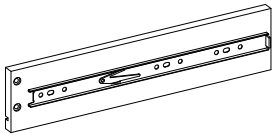

H3- Drawer Left Side (Qty. 2)

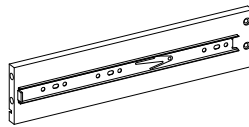

H4- Drawer Right Side Qty. 2)

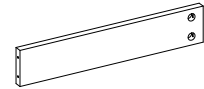

H5- Drawer Bottom Support (Qty. 2)

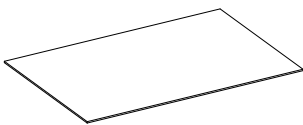

H6- Drawer Bottom Panel (Qty. 2)

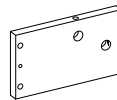

I- Desk Left Front Panel (Qty. 1)

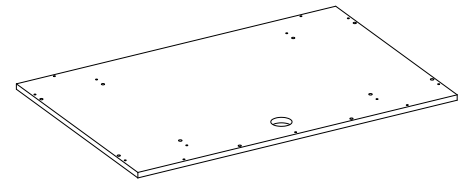

J- Return Top Panel (Qty. 1)

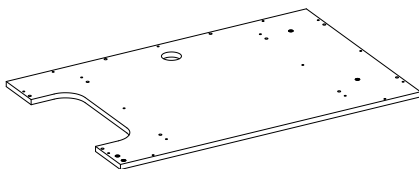

K- Return Bottom Panel (Qty. 1)

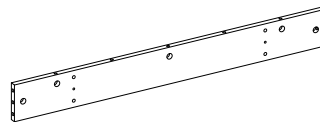

L- Return Back Panel (Qty. 1)

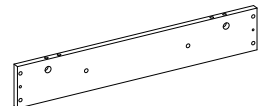

M- Return Left Side (Qty. 1)

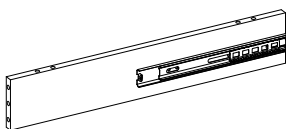

N- Return Right Partition Panel (Qty. 1)

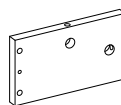

O- Return Left Front (Qty. 1)

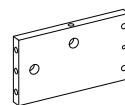

P- Return Right Front (Qty. 1)

Parts and Hardware List

Please read completely through the instructions and verify that all listed parts and hardware are present before beginning assembly.

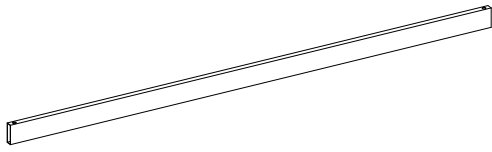

Q- Desk Long Stretcher (Qty. 1)

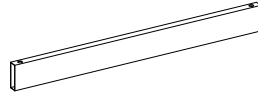

R- Desk Short Stretcher (Qty. 1)

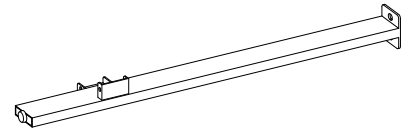

S- Desk Back Leg (Qty. 1)

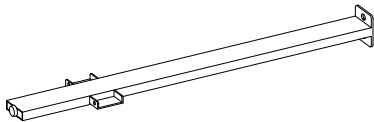

T- Desk Front Leg (Qty. 1)

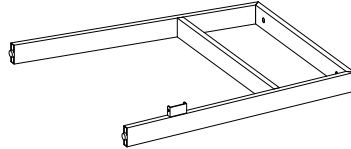

U- Desk Side Frame (Qty. 1)

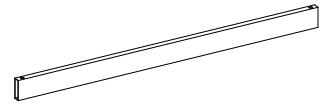

V- Return Stretcher (Qty. 1)

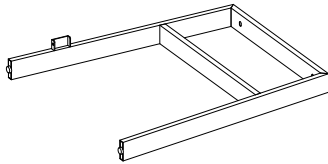

W- Return Side Frame (Qty. 1)



X- Cable Wheel (Qty. 3)

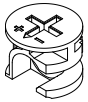

(1) Large Cam Lock
(Qty. 46+2 extra)

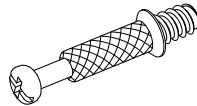

(2) Large Cam Bolt
(Qty. 46+2 extra)

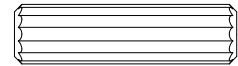

(3) M8 x 30 mm Wood Dowel
(Qty. 74+2 extra)

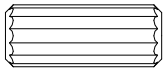

(4) M8 x 20 mm Wood Dowel
(Qty. 2+1 extra)

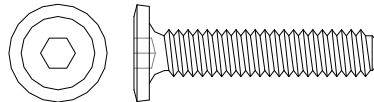

(5) 1/4" x 30 mm Bolt
(Qty. 6+1 extra)



(6) Lock Washer
(Qty. 14+1 extra)

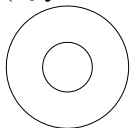

(7) Flat Washer
(Qty. 14+1 extra)

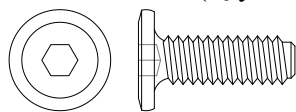

(8) 1/4" x 18 mm Bolt
(Qty. 14+1 extra)

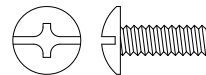

(9) 5/32" x 12 mm Bolt
(Qty. 6+1 extra)



(10) Small Cam Lock
(Qty. 12+1 extra)

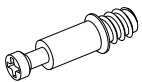

(11) Small Cam Bolt
(Qty. 12+1 extra)

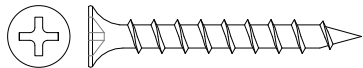

(12) M4 x 35 mm Screw
(Qty. 48+2 extra)

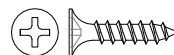

(13) M4 x 14 mm Flat Head Screw
(Qty. 4+1 extra)



(14) Handle
(Qty. 2)



(15) Grommet (Qty. 2)

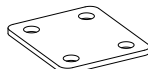

(16) Metal Bracket (Qty. 1)



Hex Wrench (Qty. 1)



Glue (Qty. 2)

Tools required: Hex wrench (provided), Phillips screwdriver and Hammer (not provided).

Drawer Assembling

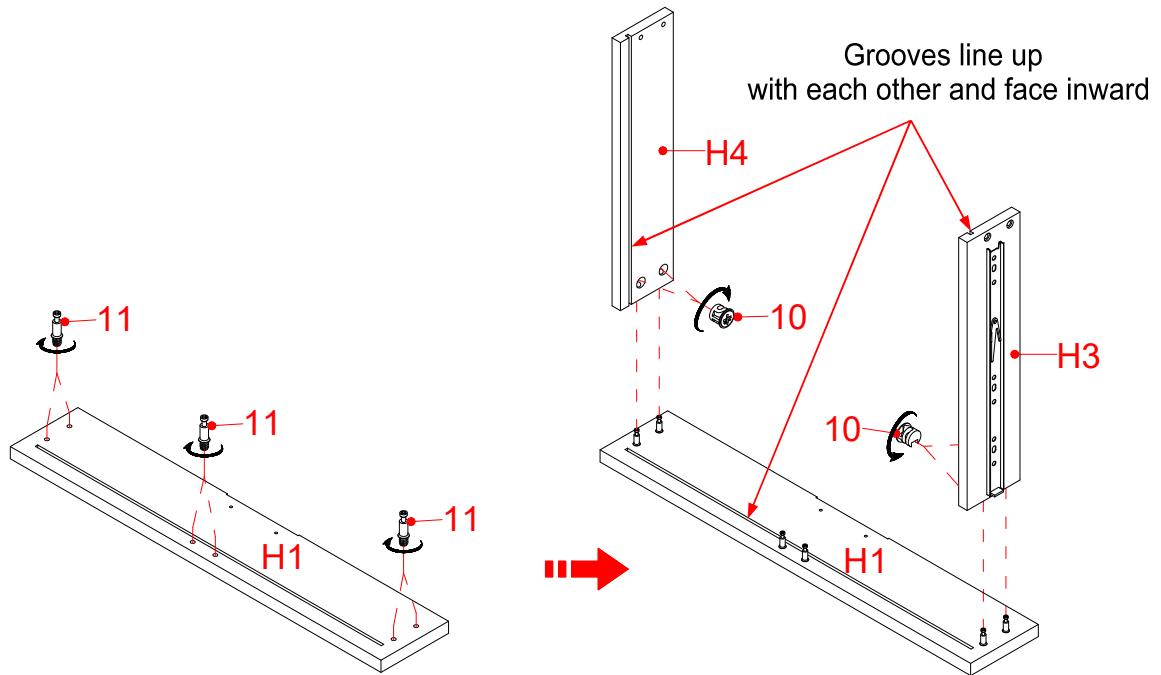

1. Unpack the unit and confirm that you have all the hardware and required parts. Assemble the unit on a carpeted floor or the empty carton to avoid any scratch.
2. Securely screw the Small Cam Bolts (11) into the designated small holes on the Drawer Front (H1) using a Phillips screwdriver.
3. Fasten the Drawer Left and Right Sides (H3 and H4) to the Drawer Front (H1) with 4 Small Cam Locks (10).

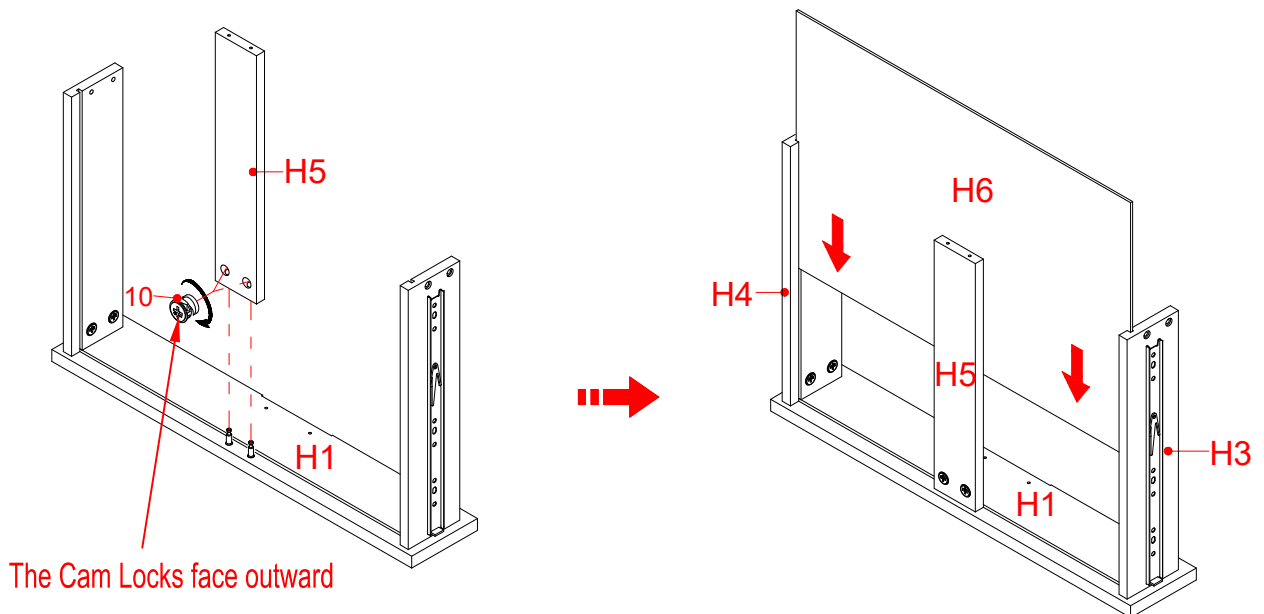

4. Fasten the Drawer Bottom Support (H5) to the Drawer Front (H1) with 2 Small Cam Locks (10).
5. Slide the Drawer Bottom Panel (H6) all the way into the grooves.

Drawer Assembling

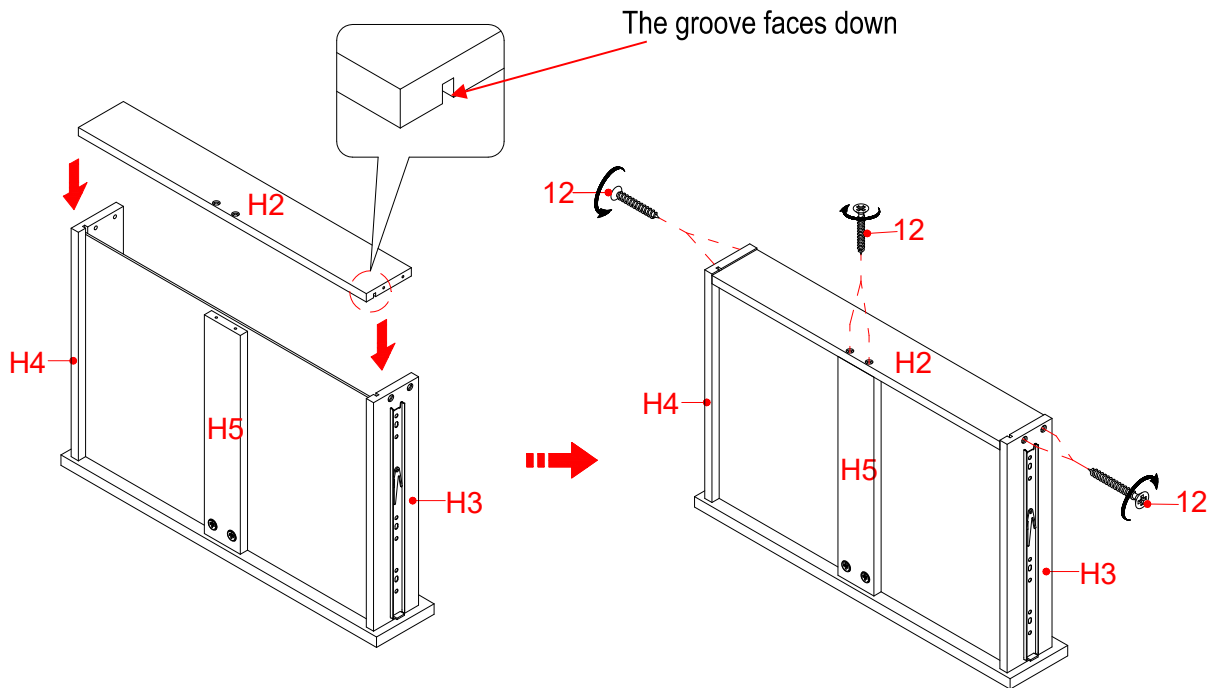

6. Fasten the Drawer Back Panel (H2) to the Drawer Side Panels (H3 and H4) and Bottom Support (H5) with six 35 mm Screws (12). Make sure that the Drawer Bottom Panel (H6) fits securely into the groove of the Drawer Back Panel (H2).

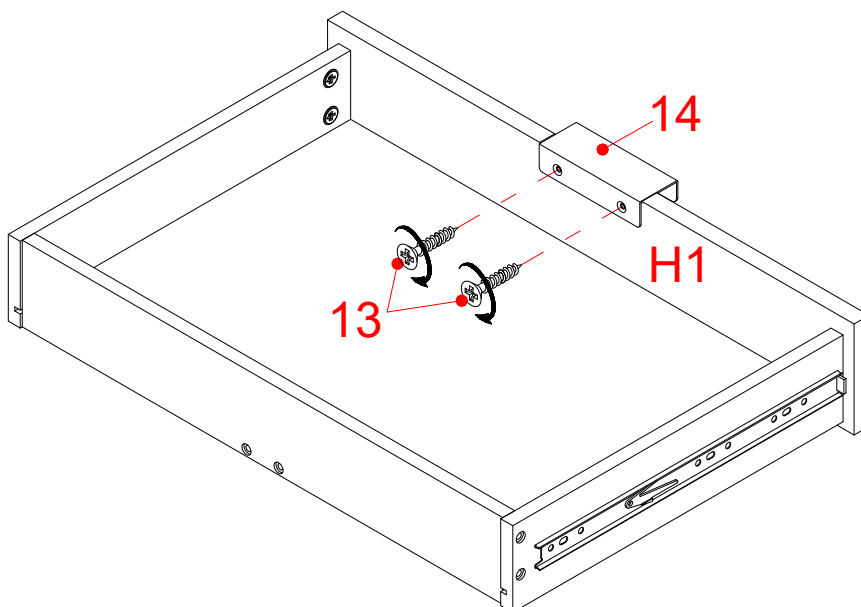

7. Turn the assembled drawer upright. Attach the Handle (14) to the pilot holes on the Drawer Front (H1) with two 14 mm Flat Head Screws (13).
8. Repeat the same procedure to assemble the other drawer.

Desk Assembling

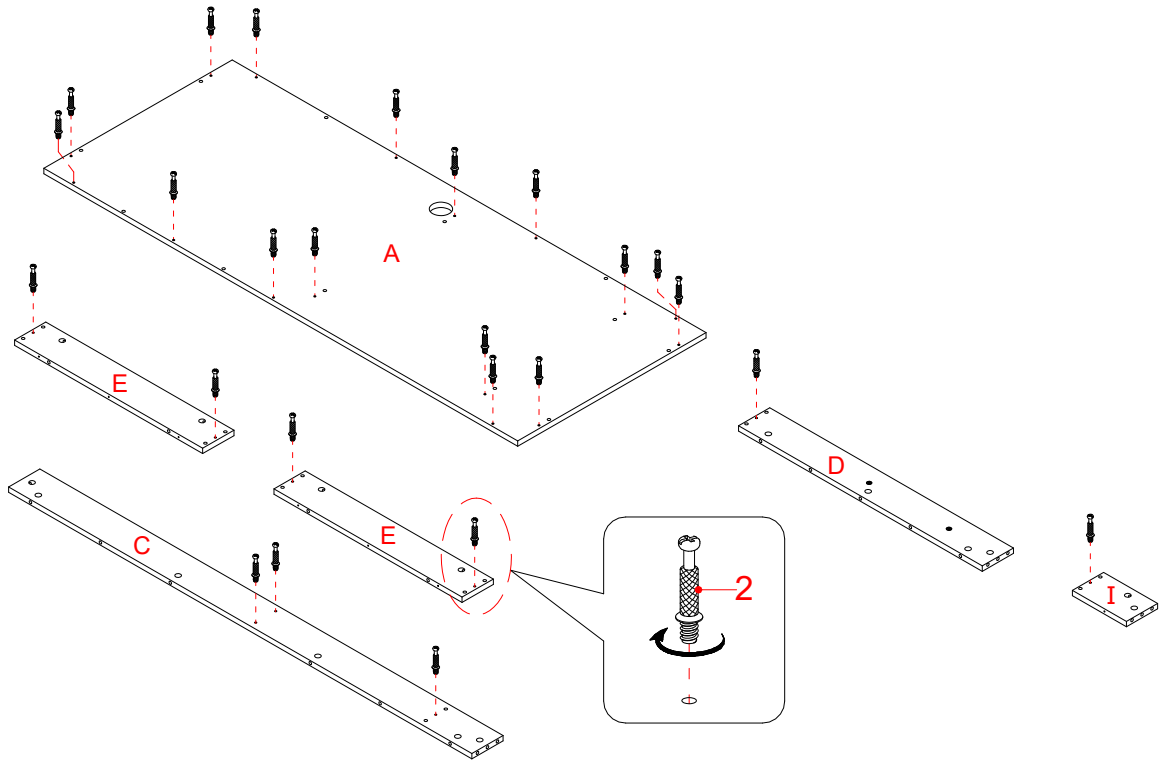

9. Securely screw the Large Cam Bolts (2) into the designated small holes on the Desk Top Panel (A), Back Panel (C), Side Panels (E) and Front Panels (D and I) using a Phillips screwdriver.

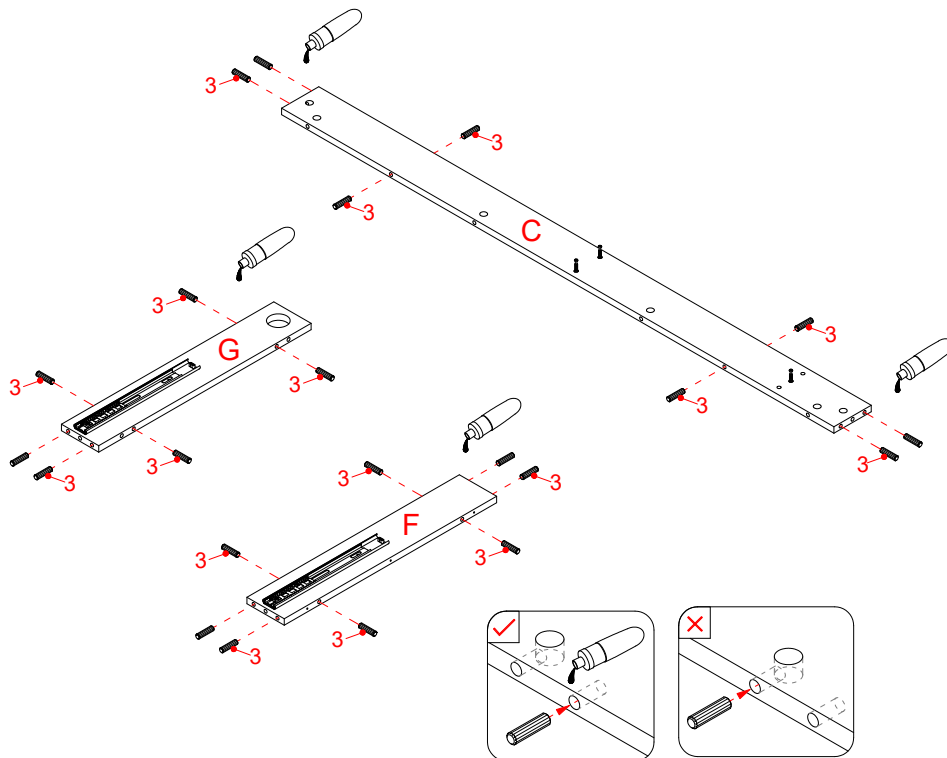

10. Glue the M8 x 30 mm Wood Dowels (3) into the inner holes of Back Panel (C) and Partition Panels (F and G).

NOTE: It is very important to use a small amount of glue on both ends of dowels.

Desk Assembling

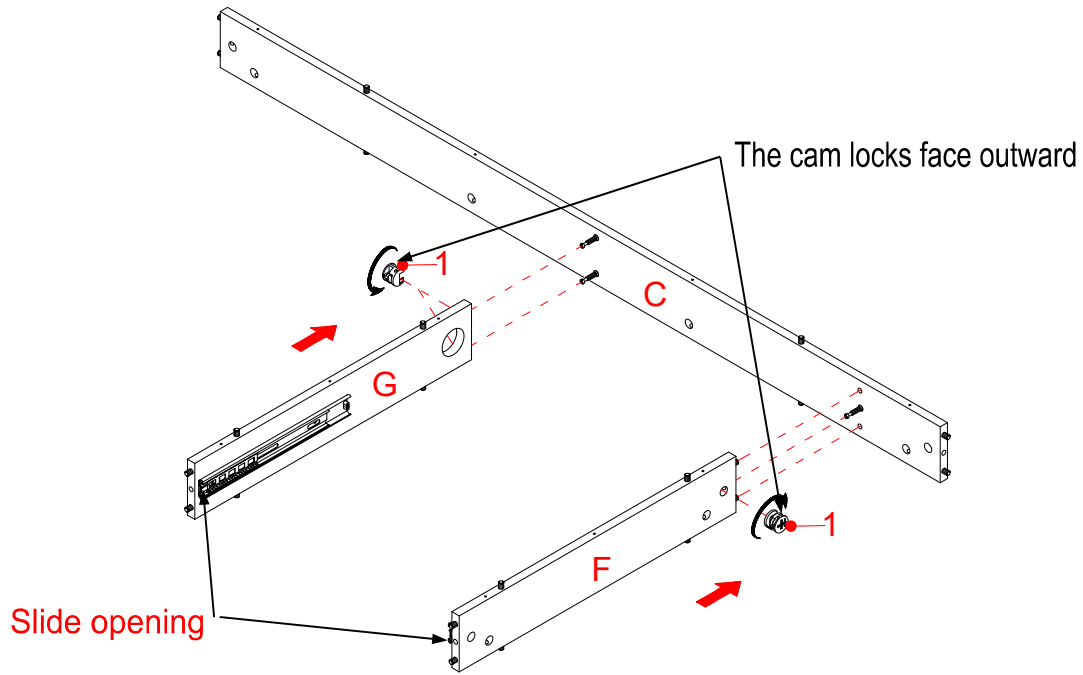

11. Align and attach the Partition Panels (F and G) to the Back Panel (C) by engaging 3 Large Cam Locks (1) (Refer to page 3 on Cam Lock system operation supplement).

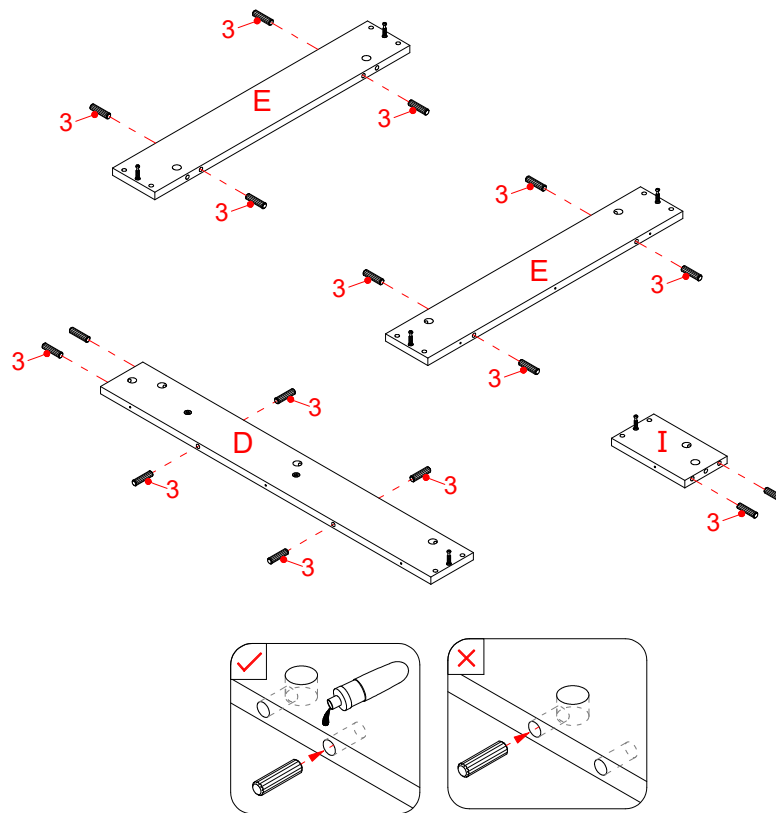

12. Glue M8 x 30 mm Wood Dowels (3) into the inner holes of Side Panels (E) and Front Panels (D and I).

Desk Assembling

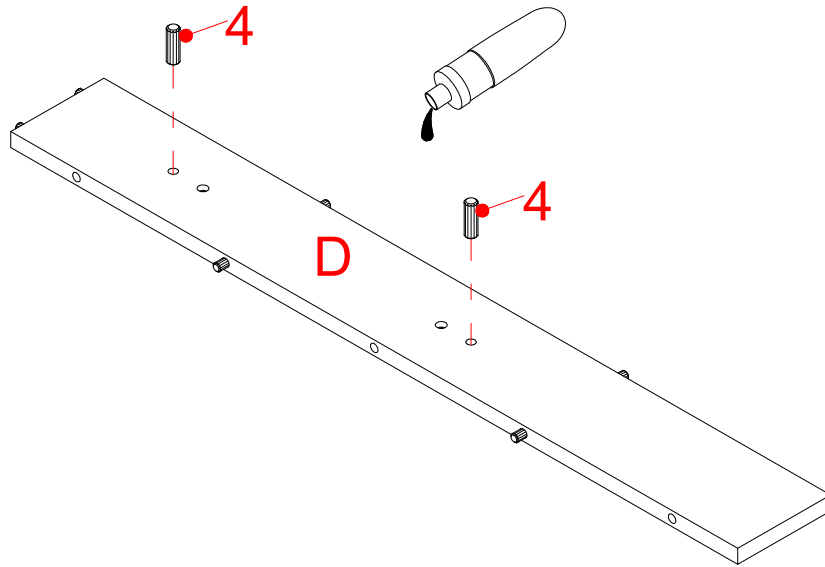

13. Glue the M8 x 20 mm Wood Dowels (4) into the inner holes of Desk Right Front Panel (D).

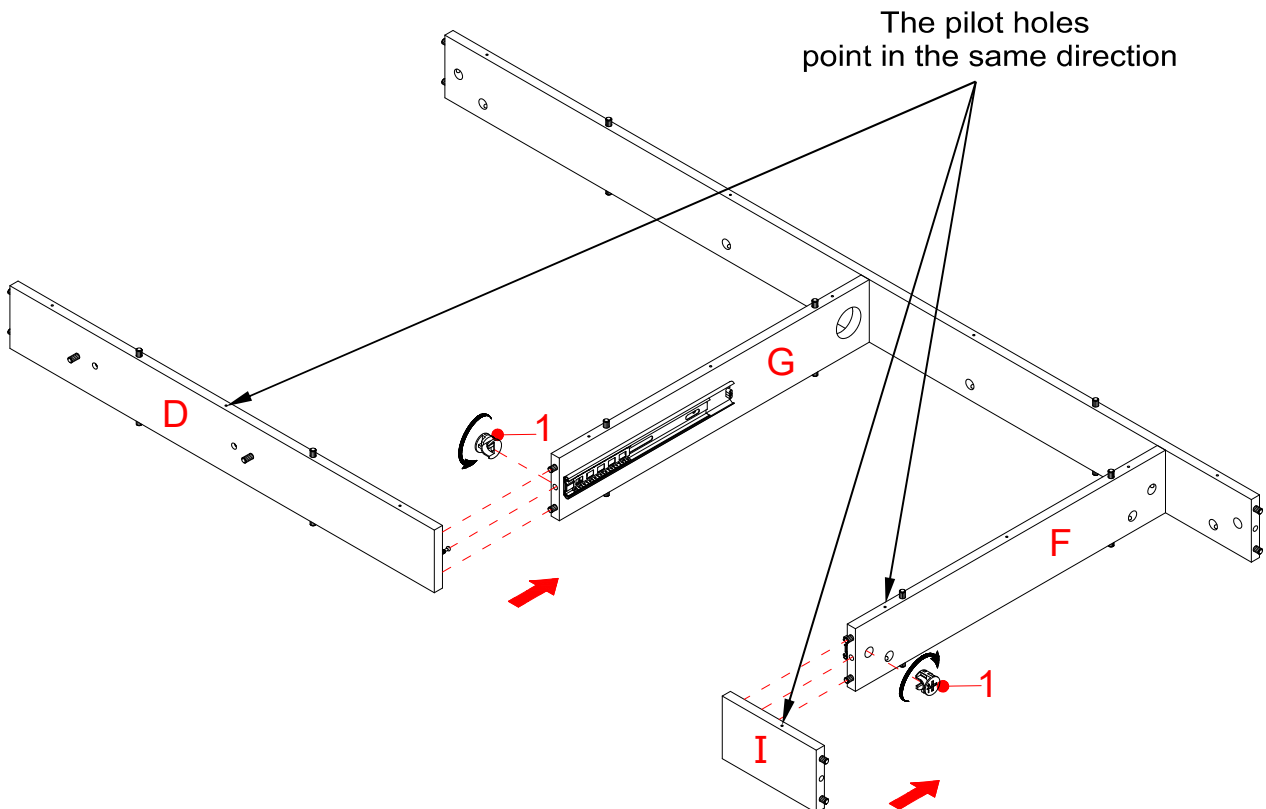

14. Attach the Desk Right Front Panel (D) to the Right Partition Panel (G) with one Large Cam Lock (1).

15. Attach the Desk Left Front Panel (I) to the Left Partition Panel (F) with one Large Cam Lock (1).

Desk Assembling

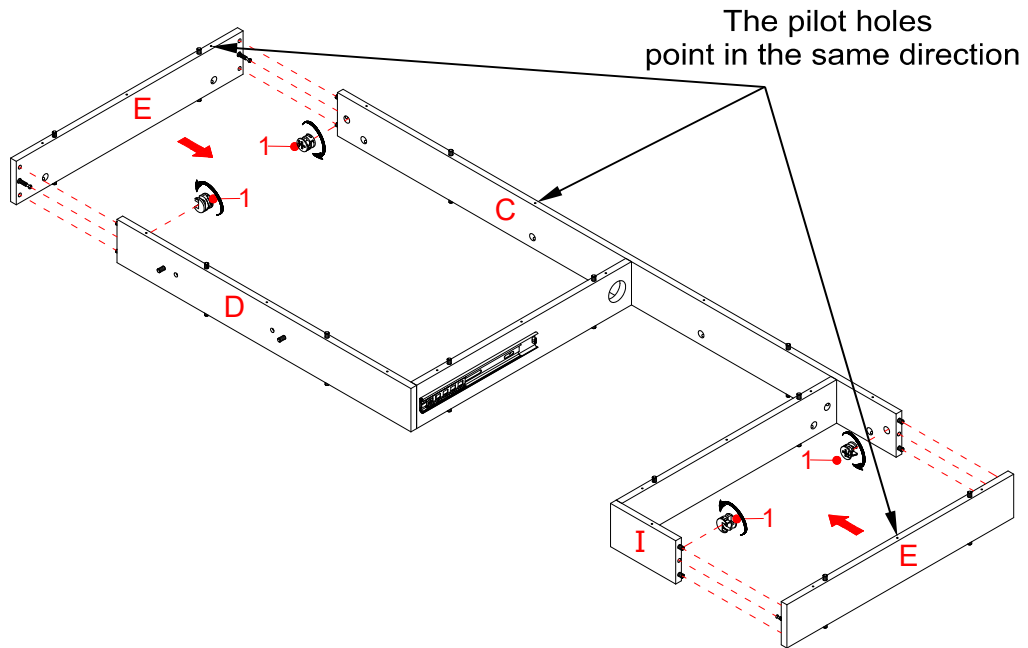

16. Align and attach the Desk Side Panels (E) to the both sides by engaging 4 Large Cam Locks (1).

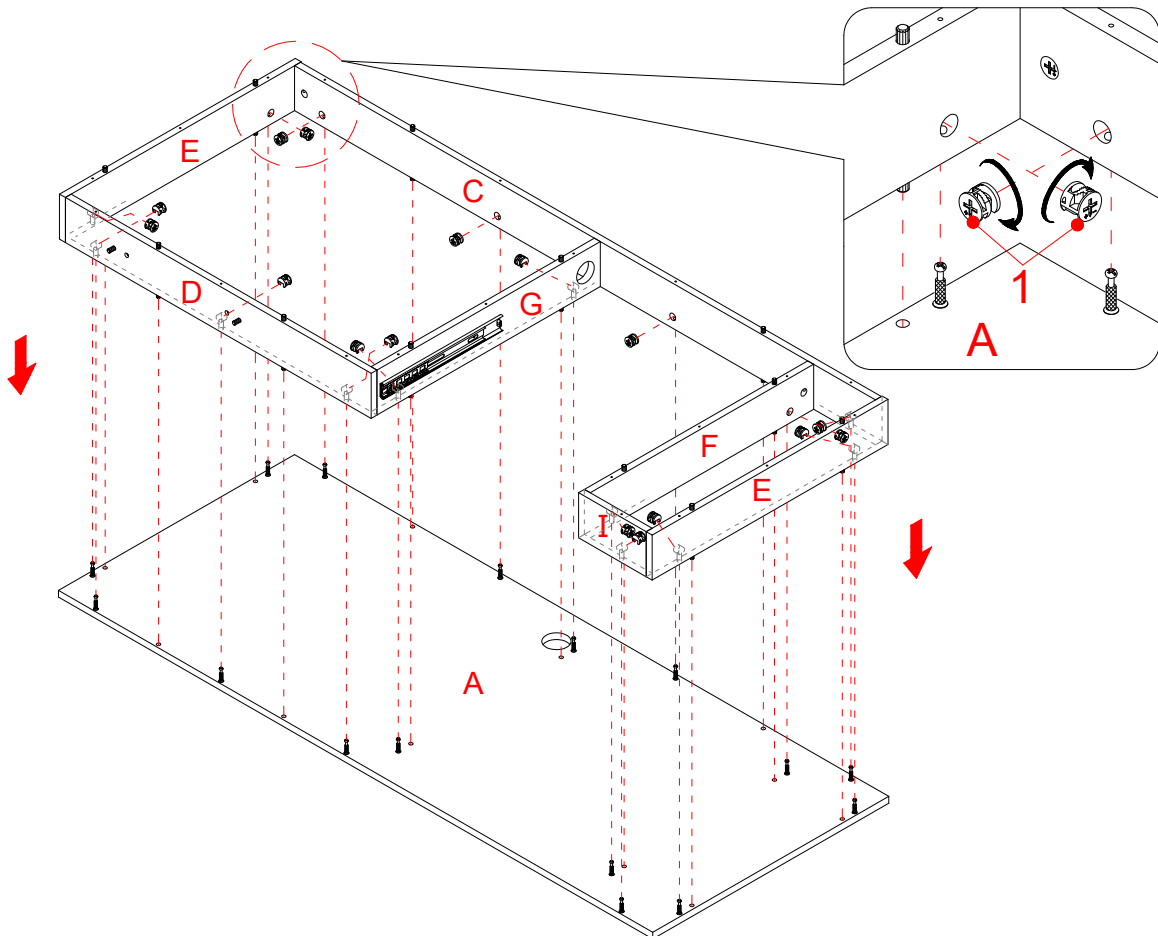

17. Align and attach the previous assembly to the Desk Top Panel (A) by engaging 16 Large Cam Locks (1).

Desk Assembling

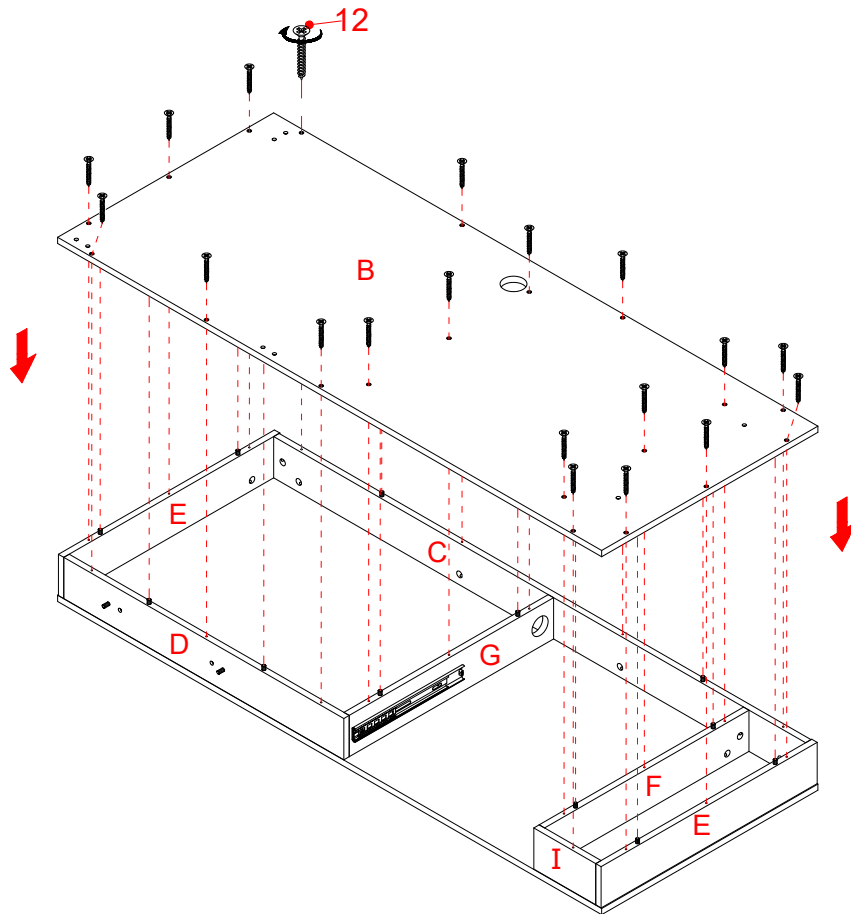

18. Attach the Desk Bottom Panel (B) to the previous assembly with the 35 mm Screws (12).

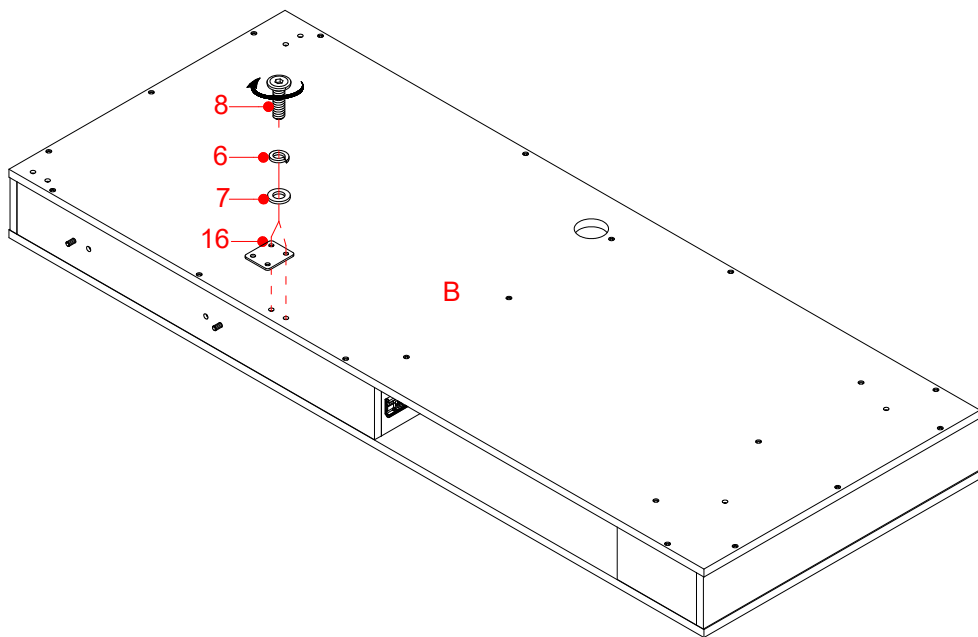

19. Attach the Metal Bracket (16) to the Desk Bottom Panel (B) with two 18 mm Bolts (8) and two Washers (6 and 7).

Desk Assembling

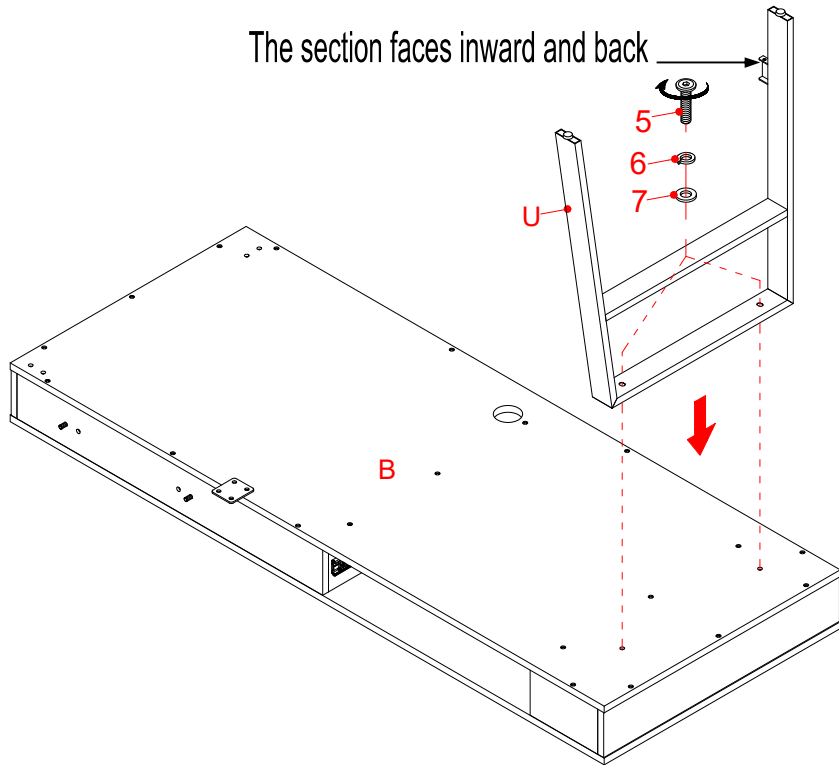

20. Attach the Desk Side Frame (U) to the Bottom Panel (B) with two 30 mm Bolts (5) and two Washers (6 and 7).

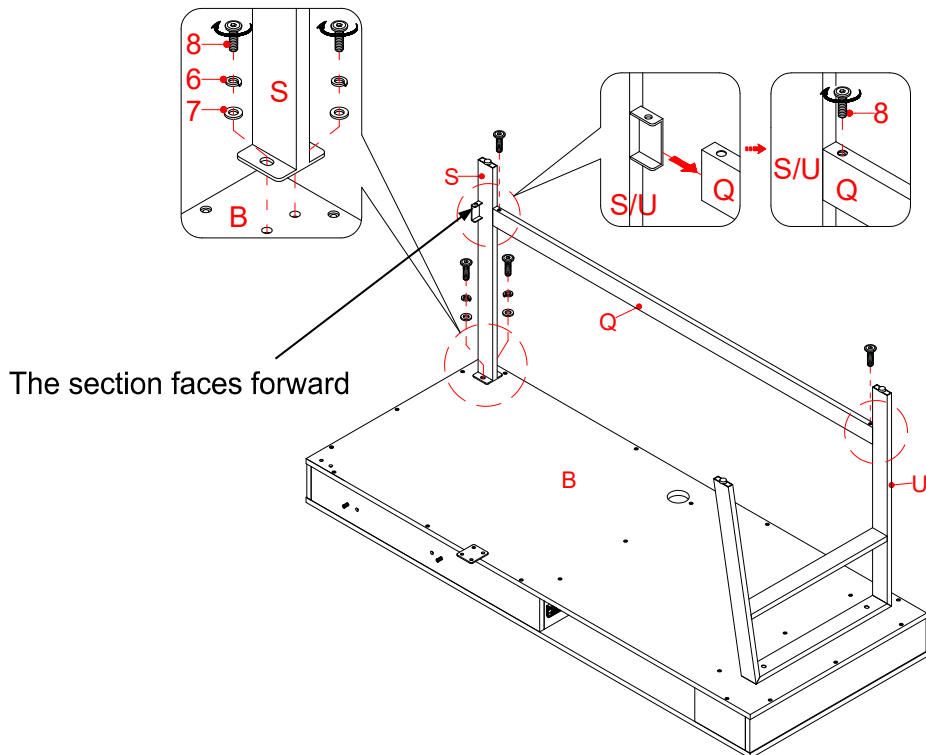

21. Attach the Desk Long Stretcher (Q) between the Desk Side Frame (U) and Desk Back Leg (S) with two 18 mm Bolts (8).
22. Fasten Desk Back Leg (S) to the Desk Bottom Panel (B) with two 18 mm Bolts (8) and two Washers (6 and 7).

Desk Assembling

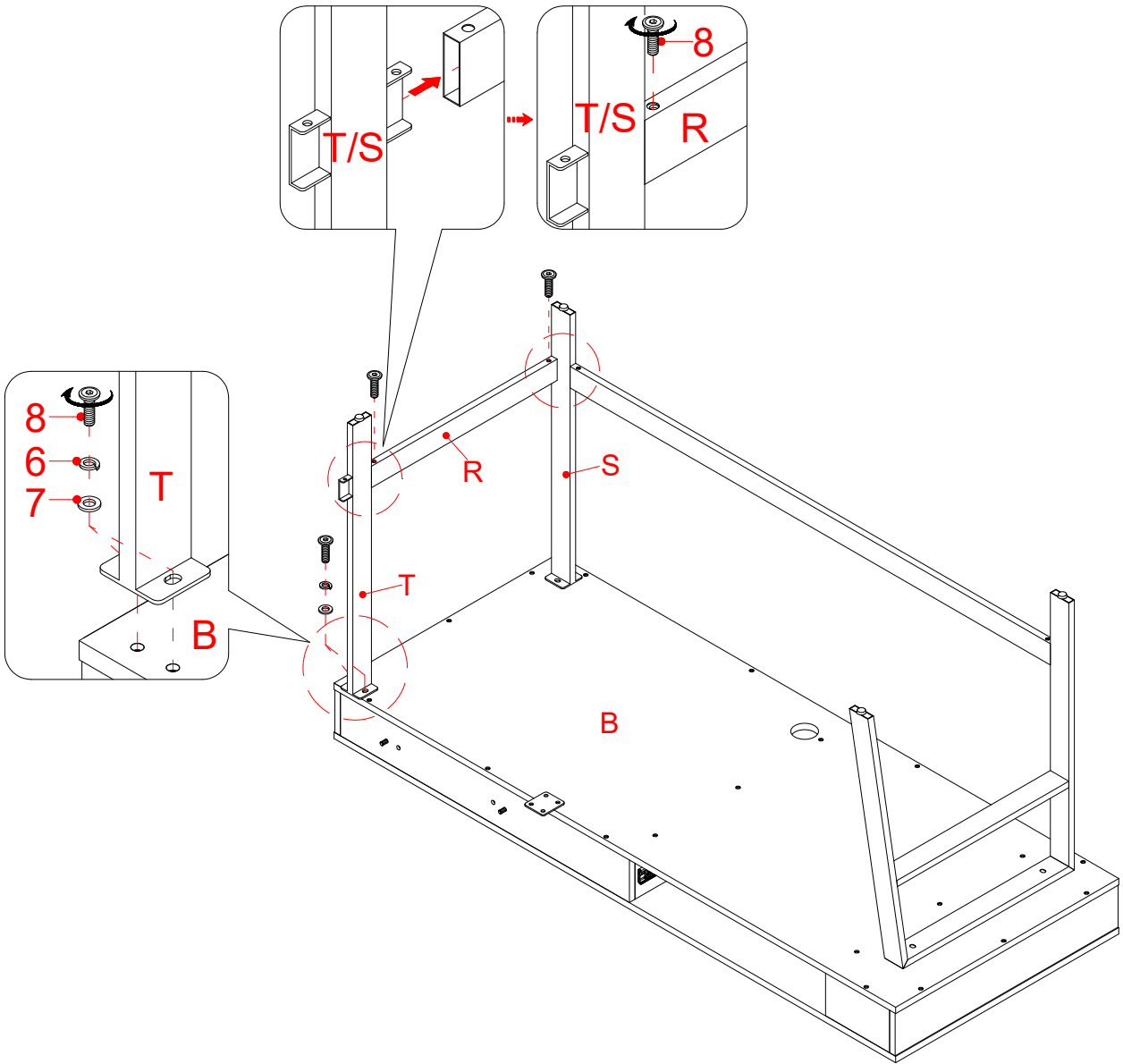

23. Attach the Desk Short Stretcher (R) between the Desk Front and Back Legs (T and S) with two 18 mm Bolts (8).

24. Fasten Desk Front Leg (T) to the Desk Bottom Panel (B) with two 18 mm Bolts (8) and two Washers (6 and 7).

Return Desk Assembling

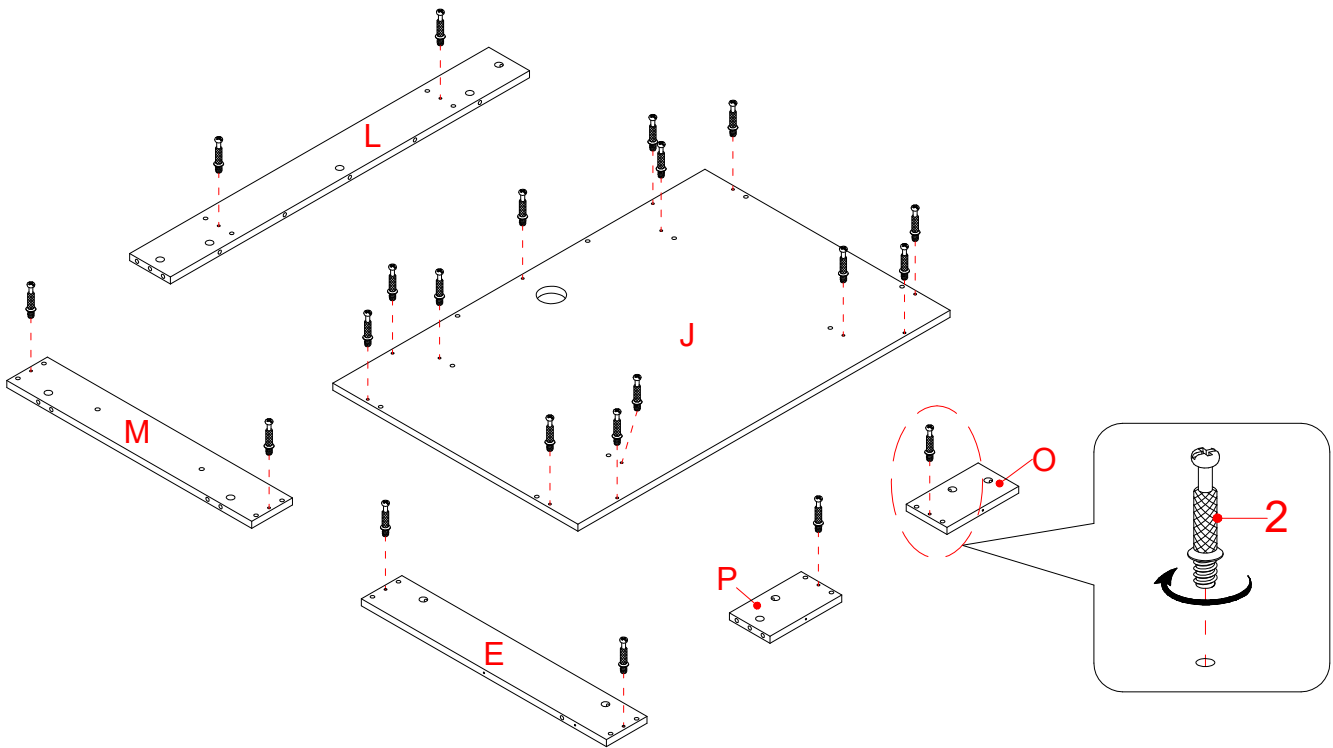

25. Securely screw the Large Cam Bolts (2) into the designated small holes on the Return Top Panel (J), Back Panel (L), Return Left Side Panel (M), Desk Side Panel (E) and Front Panels (O and P) using a Phillips screwdriver.

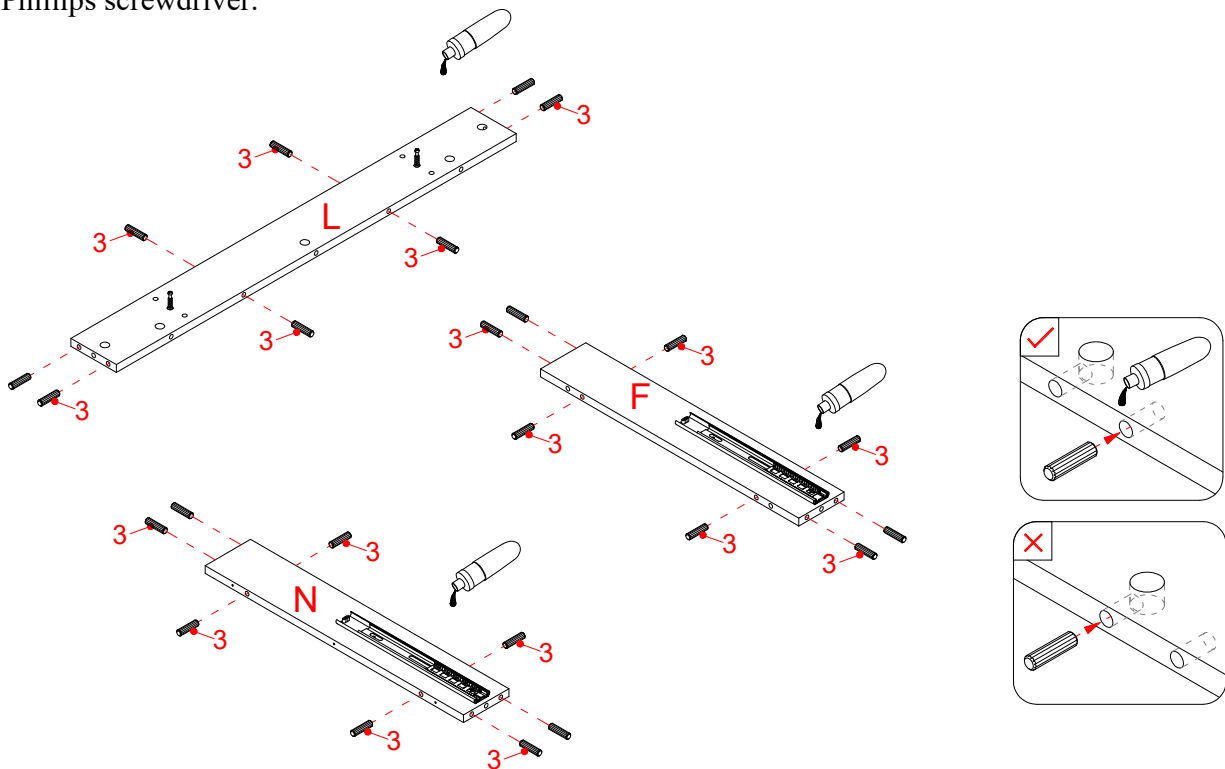

26. Glue the M8 x 30 mm Wood Dowels (3) into the inner holes of Back Panel (L) and Partition Panels (F and N). **NOTE:** It is very important to use a small amount of glue on both ends of dowels.

Return Desk Assembling

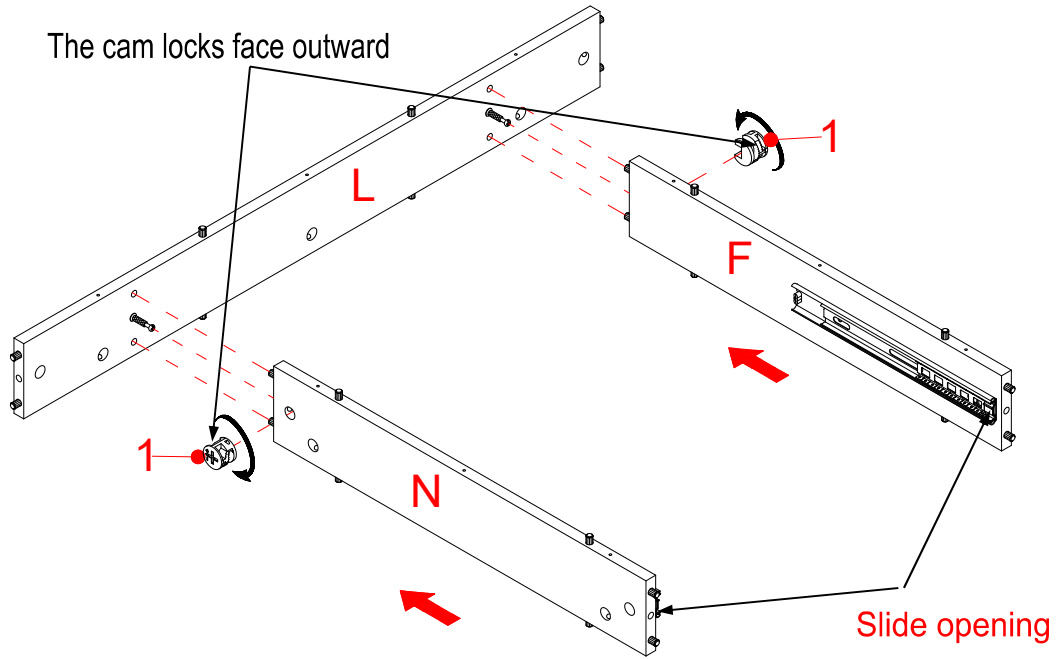

27. Align and attach the Partition Panels (F and N) to the Back Panel (L) by engaging 2 Large Cam Locks (1) (Refer to page 3 on Cam Lock system operation supplement).

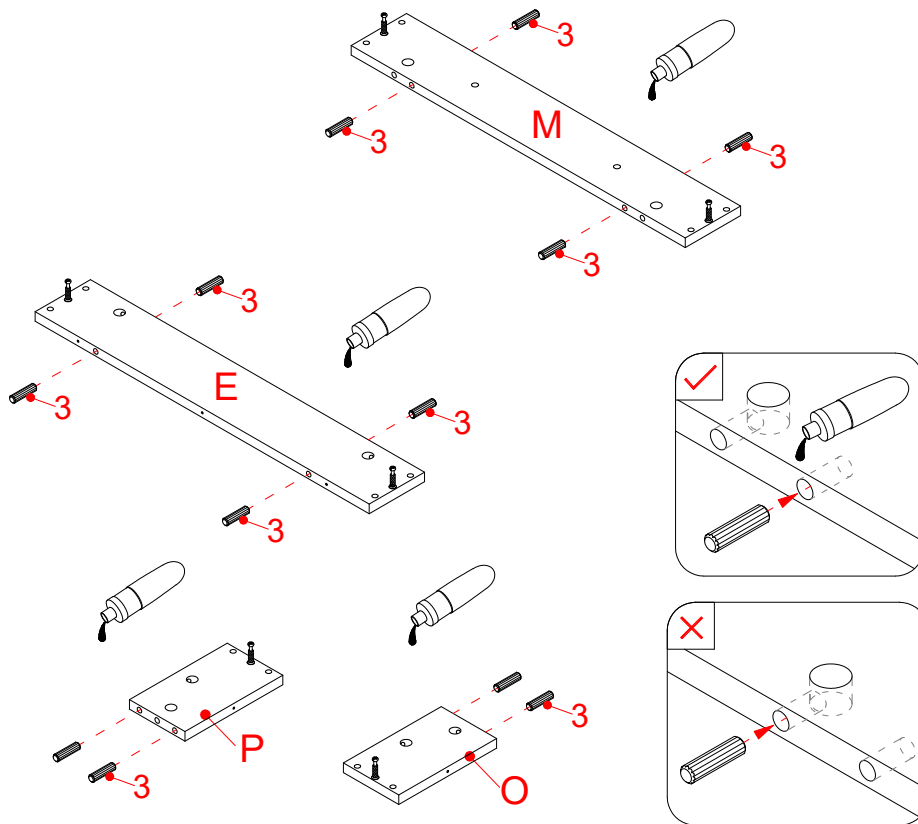

28. Glue the M8 x 30 mm Wood Dowels (3) into the inner holes of Side Panels (E and M) and Front Panels (O and P).

Return Desk Assembling

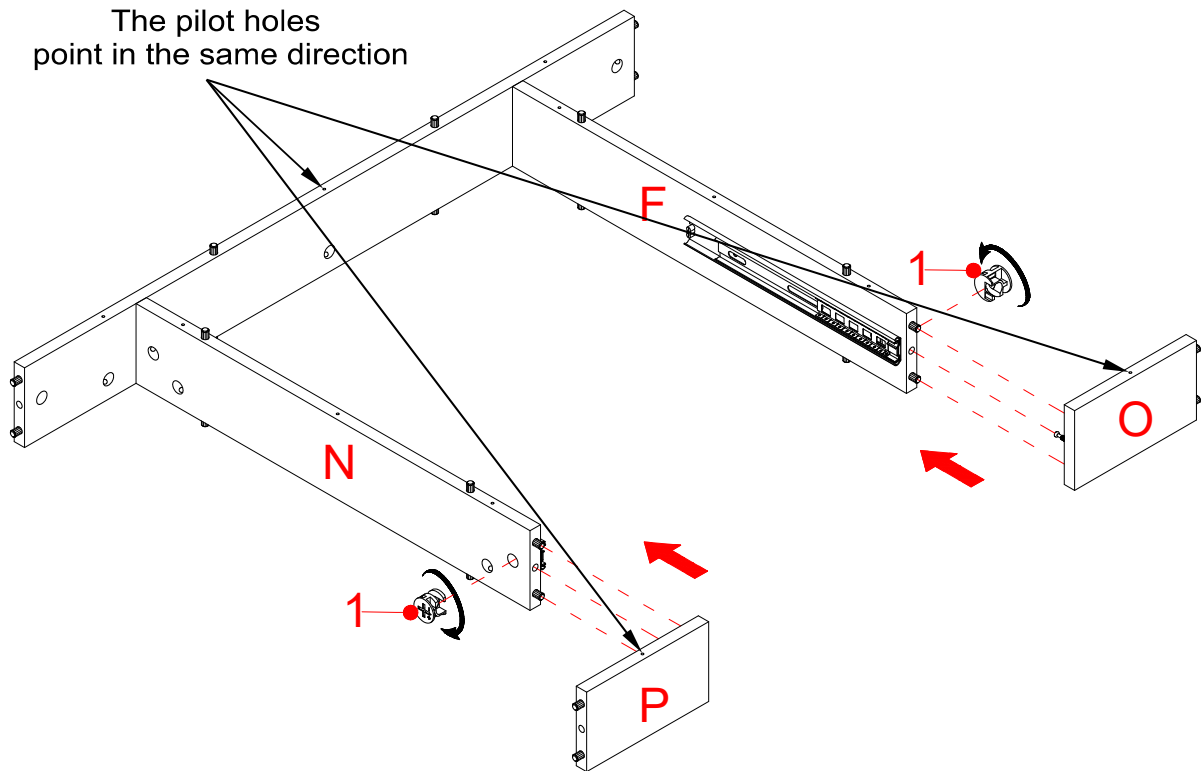

29. Attach the Return Right Front Panel (P) to the Right Partition Panel (N) with one Large Cam Lock (1).
30. Attach the Return Left Front Panel (O) to the Left Partition Panel (F) with one Large Cam Lock (1).

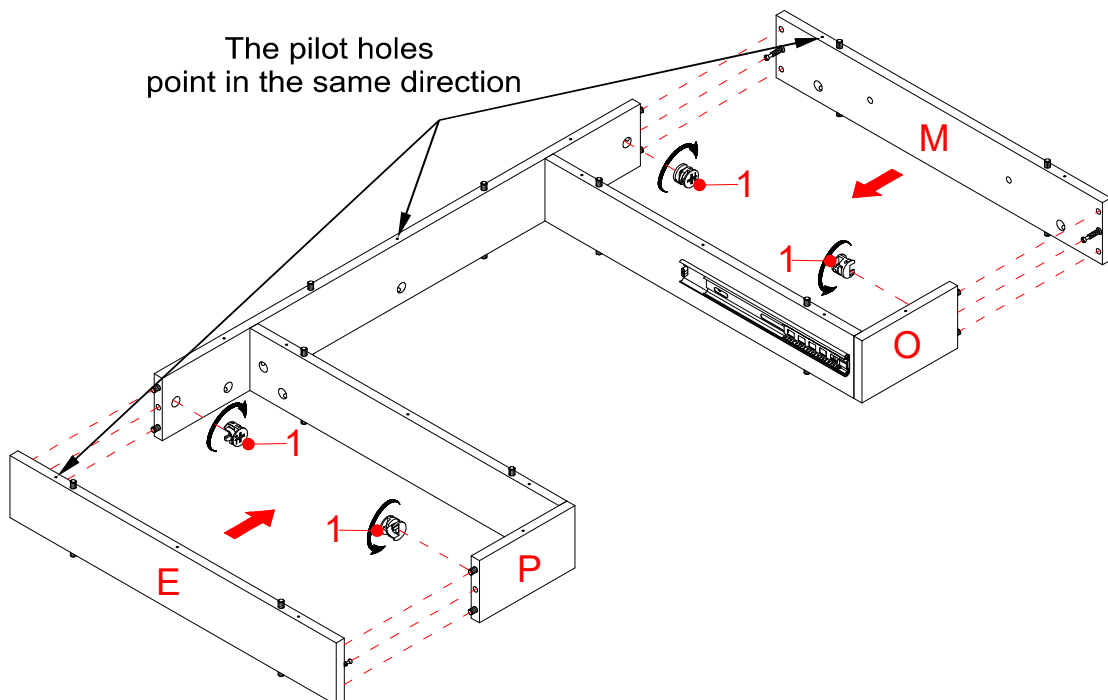

31. Attach the Desk Side Panel (E) to the Return Right Front Panel (P) and the Back Panel (L) by engaging 2 Large Cam Locks (1).
32. Attach the Return Left Side (M) to the Return Left Front Panel (O) and the Back Panel (L) by engaging 2 Large Cam Locks (1).

Return Desk Assembling

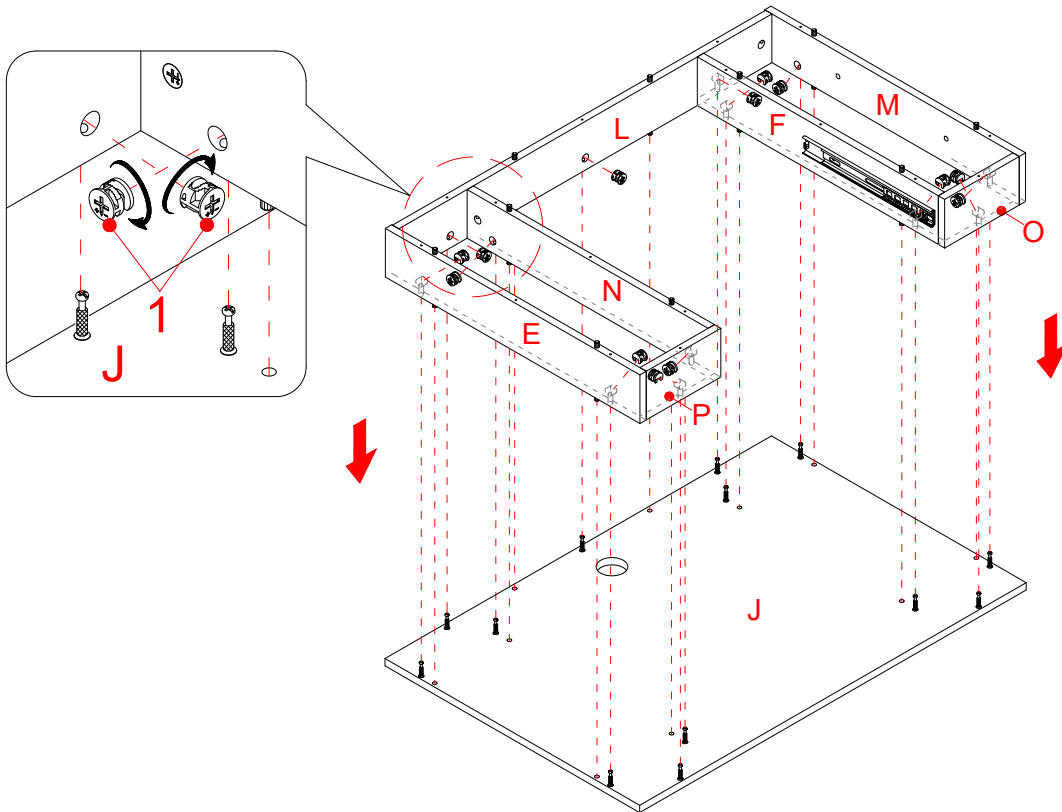

33. Align and attach the previous assembly to Return Top Panel (J) by engaging 13 Large Cam Locks (1).

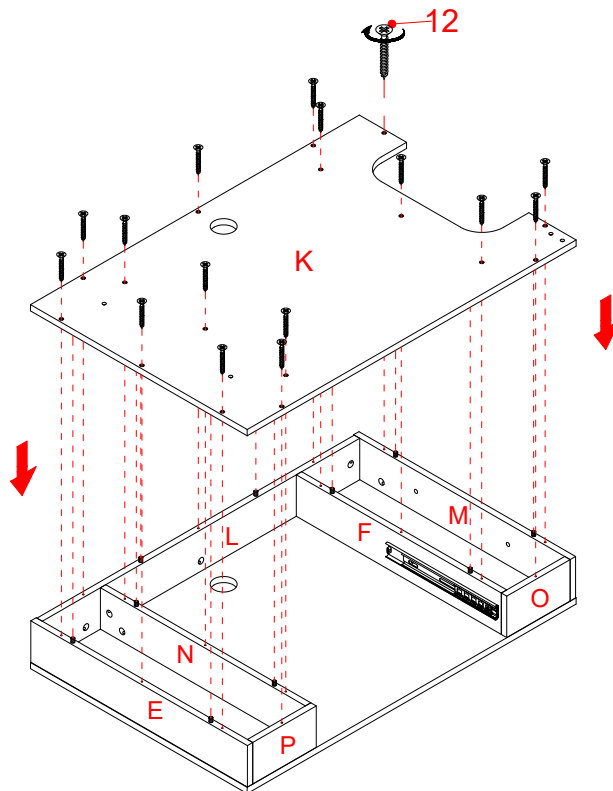

34. Attach the Return Bottom Panel (K) to the previous assembly with the 35 mm Screws (12).

Return Desk Assembling

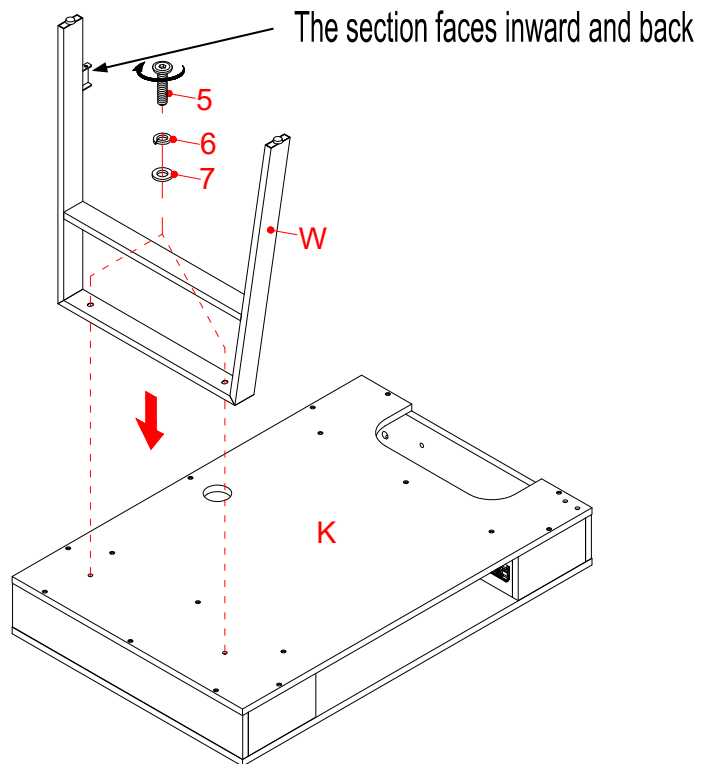

35. Attach the Return Side Frame (W) to the Bottom Panel (K) with two 30 mm Bolts (5) and two Washers (6 and 7).

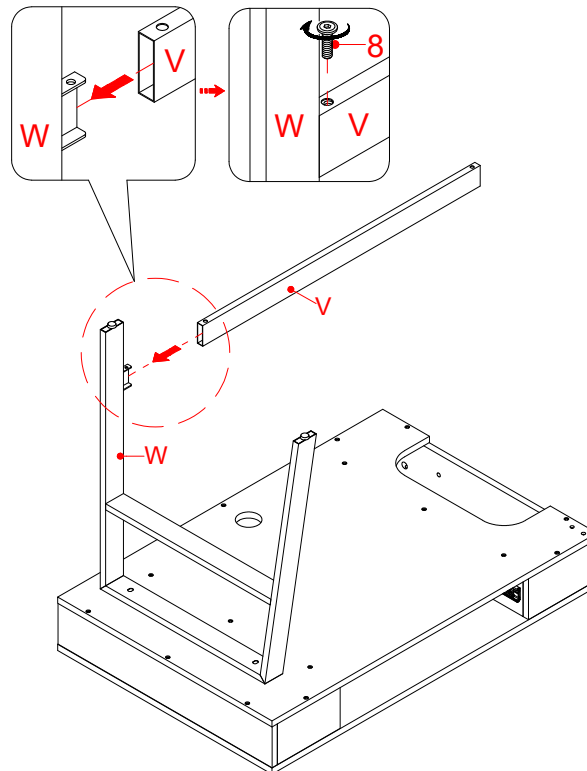

36. Attach the Return Stretcher (V) to the Side Frame (W) with one 18 mm Bolt (8).

Assembly Instructions

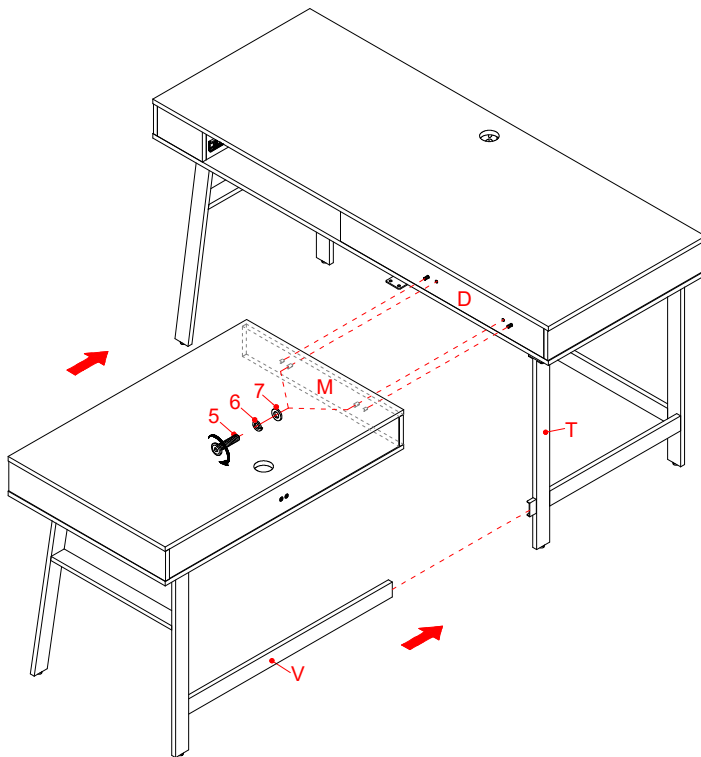

37. Ask for assistance to stand the assembled desks upright and position near the final installation location.
38. Align and attach the assembled return to the desk with two 30 mm Bolts (5) and two Washers (6 and 7).
39. Attach the Return Stretcher (V) to the Desk Front Leg (T).

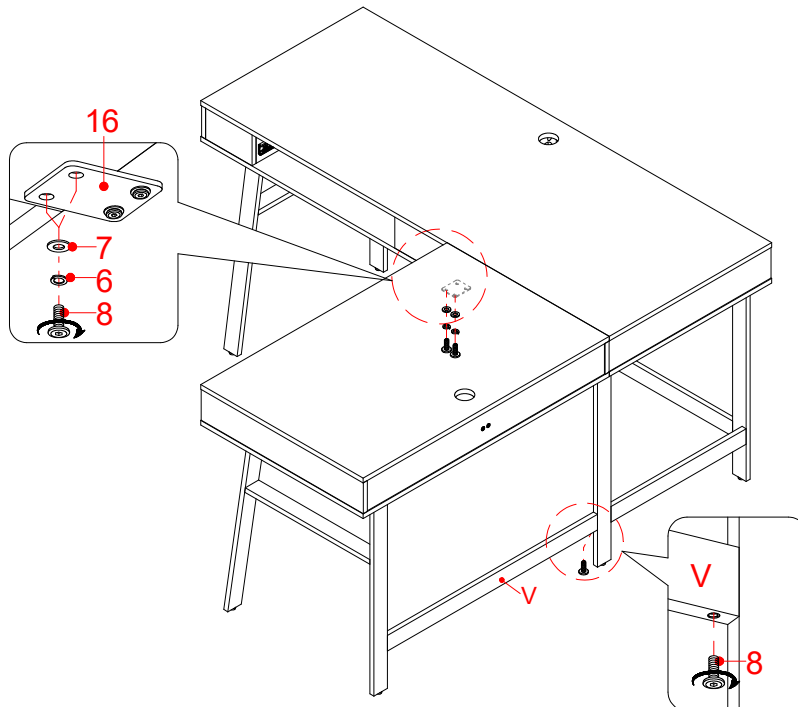

40. Secure the Metal Bracket (16) to the Return Bottom Panel (K) with two 18 mm Bolts (8) and two Washers (6 and 7).
41. Attach the Return Stretcher (V) to the Desk Front Leg (T) with one 18 mm Bolt (8).

Assembly Instructions

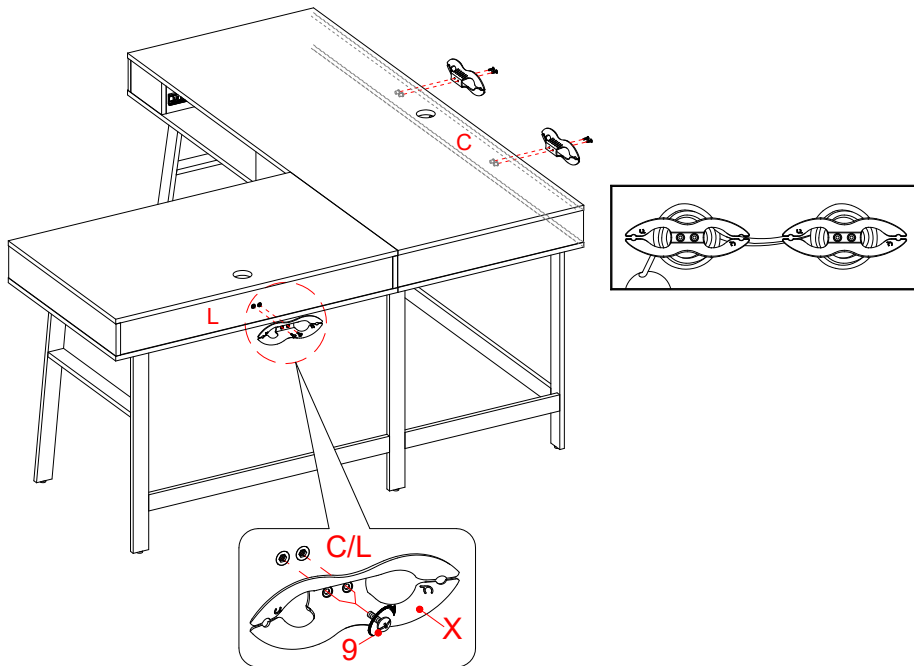

42. Attach 2 Cable Wheels (X) to the Back Panels (C and L) with the 12 mm Bolts (9).

NOTE: You can use the Cable Wheels to help keep your entertainment center's cables and cords organized.

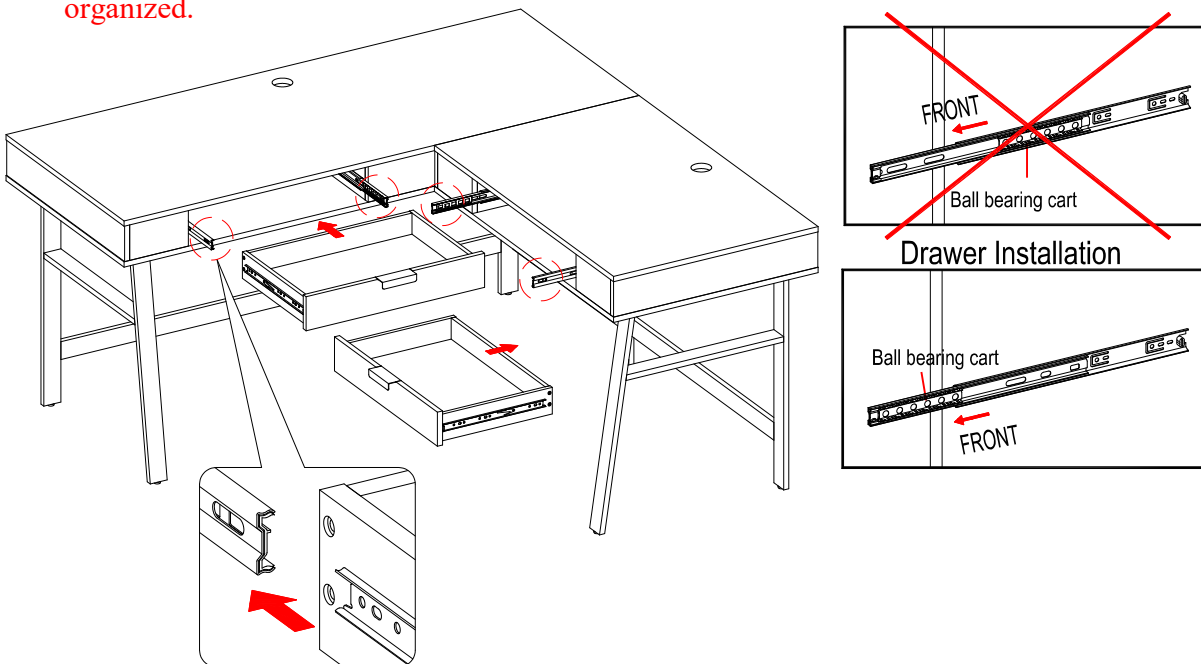

43. Insert the assembled drawers into frame. To insert the assembled drawers into your unit, extend the Ball Bearing Slide Tracks on the Partition Panels (F, G and N) all the way forward (including ball bearing cart). Then, align the Slide Runners on the assembled drawers with the Slide Tracks and push the drawer carefully inside until it stops.

NOTE: If the drawer does not go in smoothly, please take it out and repeat the step. If you need to remove the drawer, please pull the drawer all the way out, then simultaneously push the plastic release lever of the ball bearing slides up on one side and down on the other side, and then pull it completely out.

Assembly Instructions

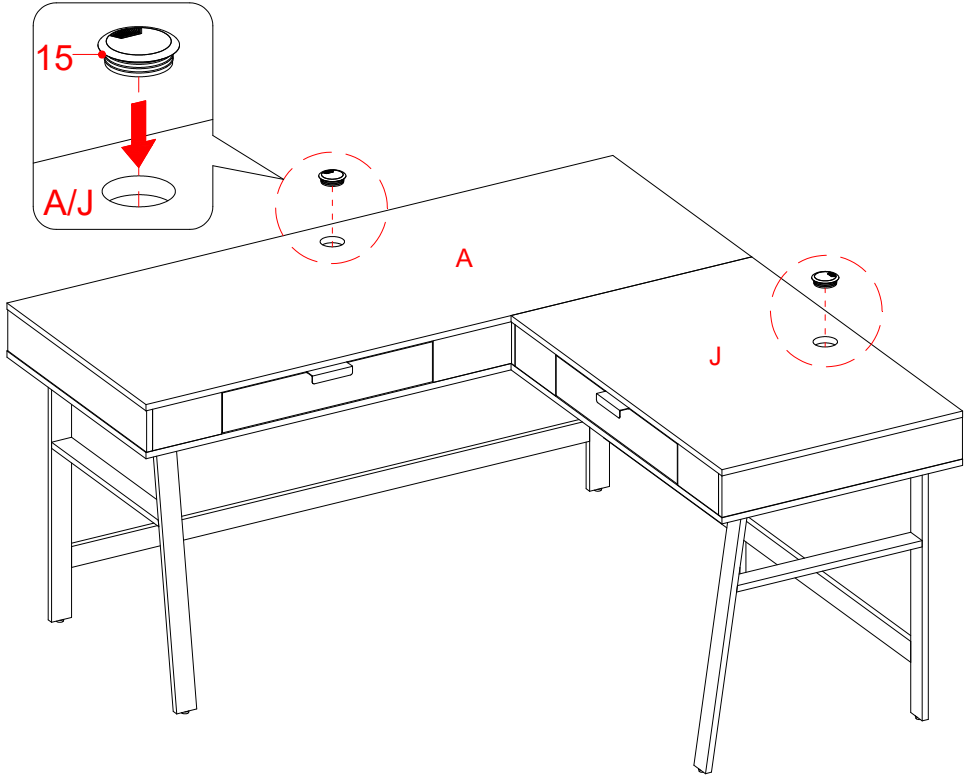

44. Insert the Grommets (15) to cover the holes in the Top Panels (A and J).

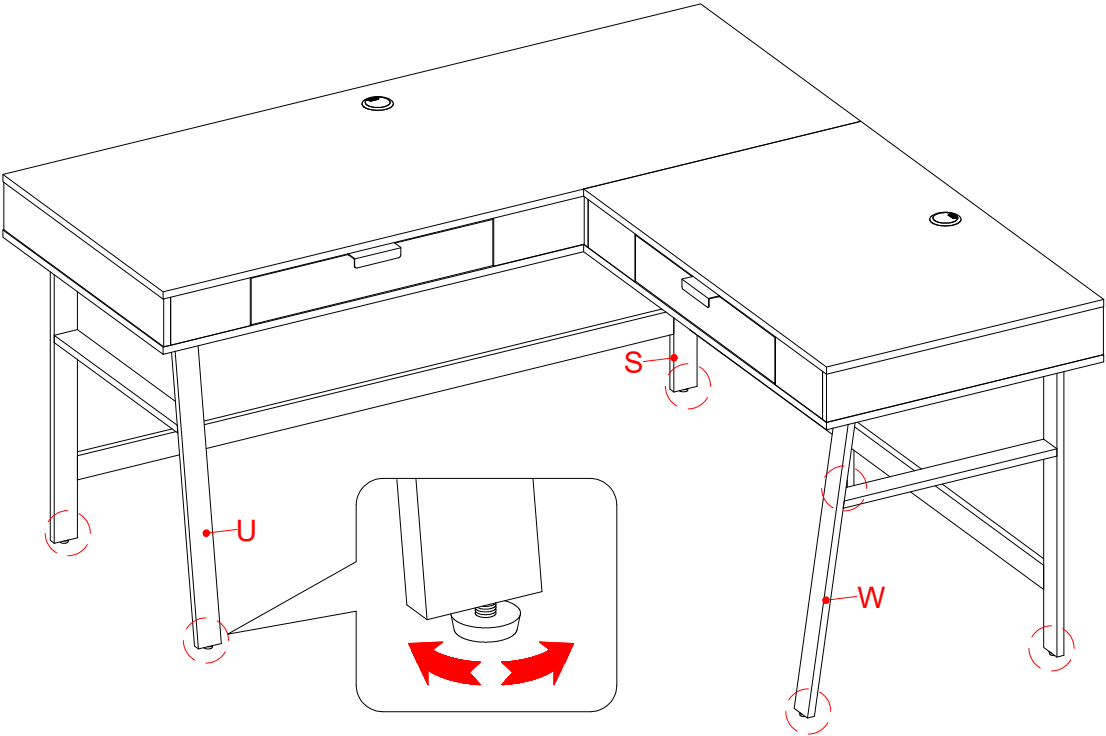

45. If necessary, adjust the pre-attached Floor Levelers at the bottom of both Legs to level the unit.

Care and Maintenance

- Use a soft, clean cloth that will not scratch the surface when dusting.
- Use of furniture polish is not necessary. Should you choose to use polish, test first in an inconspicuous area.
- Using solvents of any kind on your furniture may damage your furniture's finish.
- Never use water to clean your furniture as it may cause damage to the finish.
- Always use coasters under beverage glasses and flowerpots.
- Liquid spills should be removed immediately. Using a soft, clean cloth, blot the spill gently. Avoid rubbing.
- Always use protective pads under hot dishes and plates. Heat can cause chemical changes that may create spotting within the furniture finish.
- In the event that your furniture is stained or otherwise damaged during use, we recommend that you call a professional to repair your furniture.
- Check bolts/screws periodically and tighten them if necessary.

Further Advice about Wood Furniture Care

It is best to keep your furniture in a climate-controlled environment. Extreme temperature and humidity changes can cause fading, warping, shrinking and splitting of wood. It is advised to keep furniture away from direct sunlight as sun may damage the finish.

Proper care and cleaning at home will extend the life of your purchase. Following these important and helpful tips will enhance your furniture as it ages.

We hope you enjoy your purchase for many years.
Thank you for your purchase!

QUALITY GUARANTEE

We are confident that you will be delighted with your Whalen Furniture purchase.

Should this product be defective in workmanship or materials or fail under normal use, we will repair or replace it for up to one (1) year from date of purchase. Every Whalen Furniture product is designed to meet your highest expectations. We guarantee that you will immediately see the value of our fine furniture.

This warranty gives you specific legal rights and you may also have other rights which vary from state to state or province to province.

Customer Service: 1-866-942-5362
8:30 a.m. - 4:30 p.m., PST, Monday to Friday
www.whalenfurniture.com

Bureau Timbercrest

Modèle n° 19WTLD-SPCA

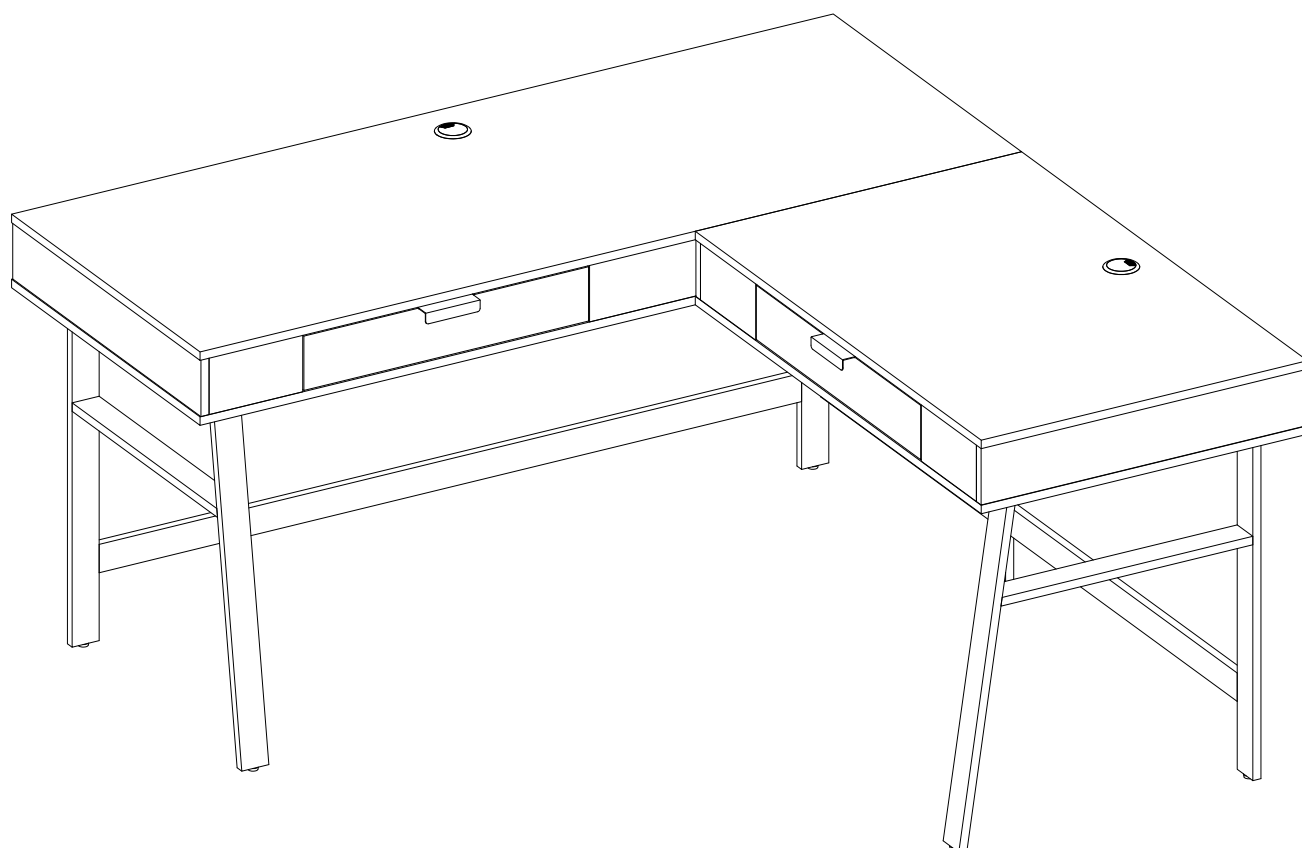

ASSEMBLAGE PAR UN ADULTE REQUIS EN RAISON DES PETITES PIÈCES, DES BOUTS POINTUS ET DES BORDS TRANCHANTS

Pour toute question sur le montage ou en cas de pièce manquante, **NE PAS** retourner cet article au point de vente. Communiquer sans frais avec notre service à la clientèle en ayant en mains les instructions et la liste des pièces pour indiquer le nom du modèle, le nom de la pièce ou le numéro d'usine :

1-866-942-5362

Heure normale du Pacifique, entre 8 h 30 et 16 h 30, du lundi au vendredi

Vous pouvez également visiter notre site Web 24 heures par jour, 7 jours sur 7 pour obtenir de

l'aide sur le produit www.whalenfurniture.com

ou transmettre une demande par courriel à parts@whalenfurniture.com

**CE LIVRET CONTIENT D'IMPORTANTES CONSIGNES DE SÉCURITÉ.
LIRE ET CONSERVER POUR RÉFÉRENCE FUTURE.**

POIDS MAXIMAL RECOMMANDÉ

FABRICANT : Whalen Furniture Manufacturing

CATALOG : Bureau Timbercrest

Modèle n° : 19WTLD-SPCA

FABRIQUÉ EN CHINE

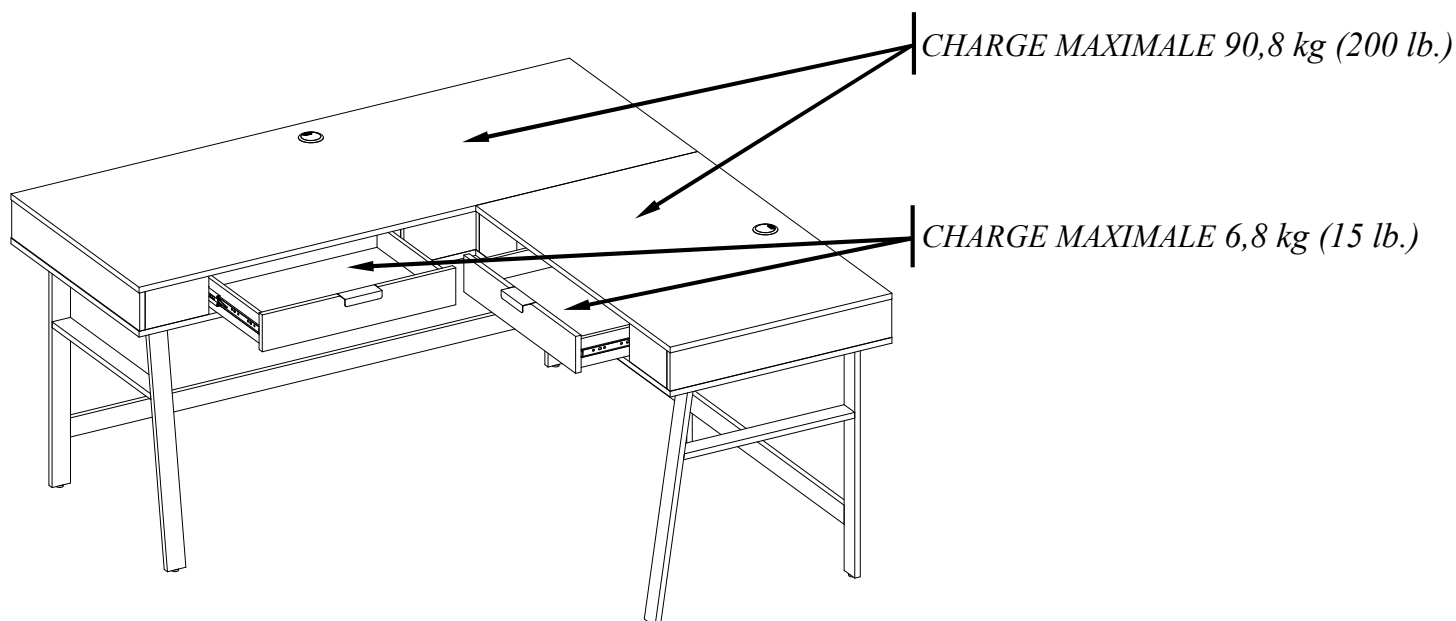

CETTE UNITÉ DOIT ÊTRE UTILISÉE EN RESPECTANT LES POIDS MAXIMAUX INDIQUÉS. L'UTILISATION DE L'UNITÉ AVEC UNE CHARGE SUPÉRIEURE AUX POIDS MAXIMAUX INDIQUÉS PEUT CAUSER L'INSTABILITÉ, VOIRE MÊME DES BLESSURES.

REMARQUE

Veillez lire toutes les directives avant de procéder au montage. Examinez tout le matériel d'emballage avant de jeter le carton. Retirez les agrafes de ce dernier avant de le jeter. Enlevez toutes les pièces du carton et répartissez-les en groupes tel qu'indiqué sur la liste des pièces. Assurez-vous que toutes les pièces ont été incluses avant de commencer le montage. L'utilisation d'outils électriques n'est pas recommandée pour le montage.

IMPORTANT

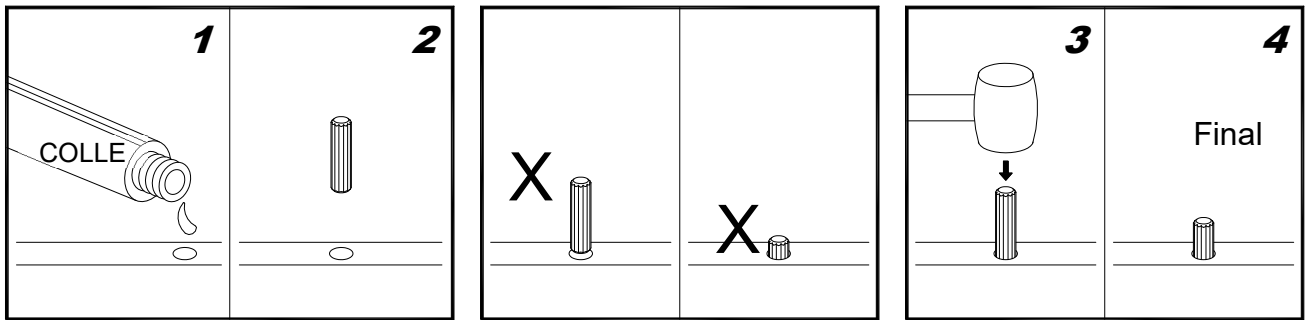

Avant de commencer : Ouvrir, identifier et compter toutes les pièces avant le montage. Étendre les pièces sur une surface plane et non abrasive. Les pièces identifiées en page 4 et 5 de ce manuel d'instructions sont requises.

REMARQUE : IL EST TRÈS IMPORTANT D'UTILISER DE LA COLLE AVEC LES GOUJONS. L'EXCÈS DE COLLE PEUT ÊTRE ESSUYÉ AVEC UN LINGE HUMIDE.

Insérer le goujon à moitié en le frappant légèrement avec un maillet de caoutchouc SI NÉCESSAIRE.

FONCTIONNEMENT DU SYSTÈME À CAME

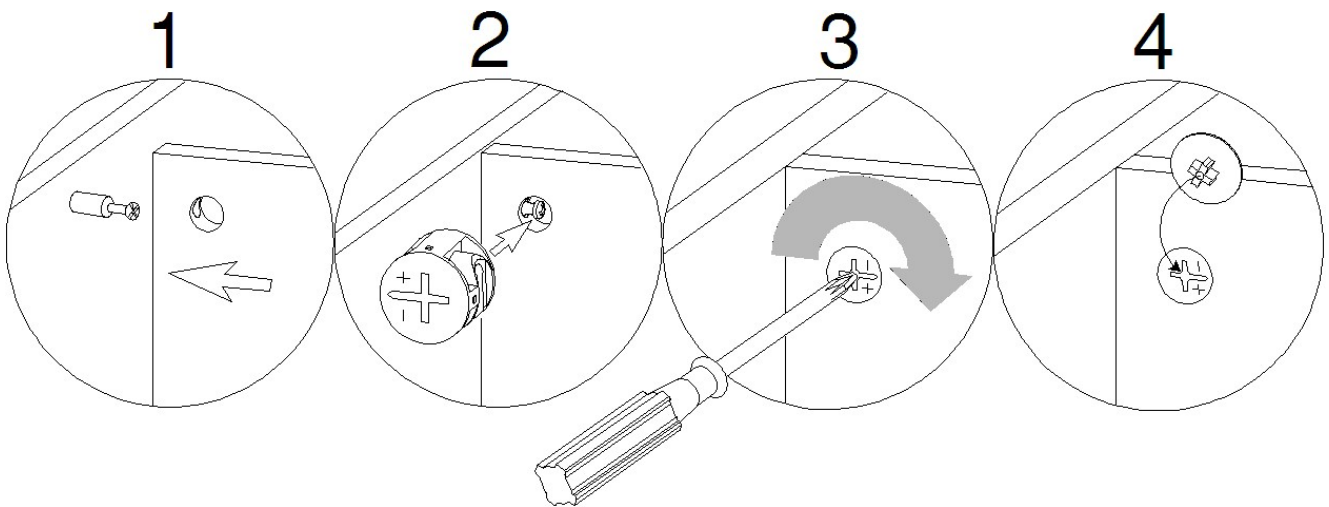

FONCTIONNEMENT DU SYSTÈME À CAME

1. Visser un boulon à came dans les petits trous déjà percés sur le panneau. Connecter les deux panneaux en s'assurant que le boulon à came s'insère dans le trou déjà percé à l'extrémité du panneau avec la came.
2. Insérer une came dans le grand trou déjà percé sur le panneau. S'assurer que la flèche sur la came soit orientée vers le boulon à came.
3. Une fois le boulon à came connecté dans la came, serrer la came dans le sens des aiguilles d'une montre avec un tournevis à pointe cruciforme.
4. Ajouter le capuchon à came dans l'ouverture en croix des cames pour les dissimuler.

L'unité est prête pour le montage.

Liste des pièces et de la quincaillerie

Lire toutes les instructions et s'assurer d'avoir toutes les pièces et la quincaillerie avant de commencer le montage.

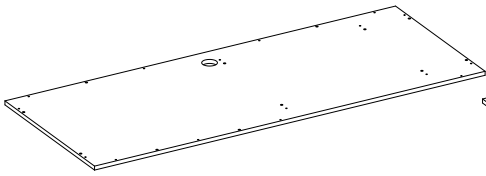

A- Panneau supérieur du bureau
(Qté. 1)

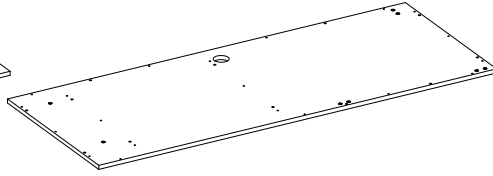

B- Panneau inférieur du bureau
(Qté. 1)

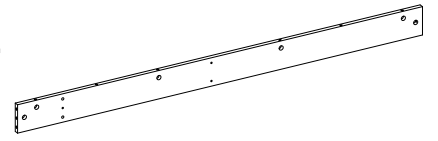

C- Panneau arrière du bureau
(Qté. 1)

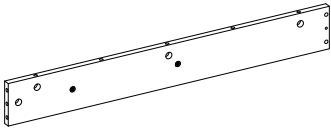

D- Panneau avant droit du bureau
(Qté. 1)

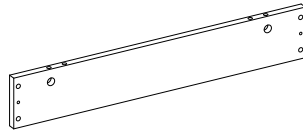

E- Panneau latéral de bureau
(Qté. 3)

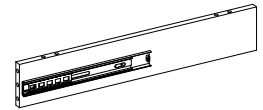

F- Panneau de séparation gauche
(Qté. 2)

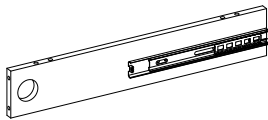

G- Panneau de séparation droit
(Qté. 1)

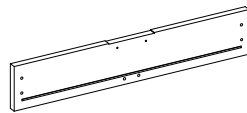

H1- Façade de tiroir
(Qté. 2)

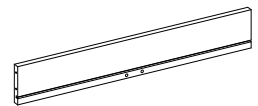

H2- Panneau arrière du tiroir
(Qté. 2)

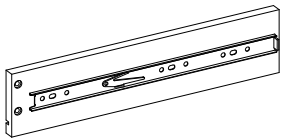

H3- Côté gauche du tiroir
(Qté. 2)

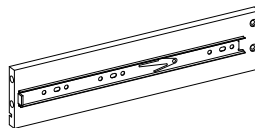

H4- Côté droit du Tiroir
(Qté. 2)

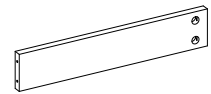

H5 - Support inférieur du tiroir
(Qté. 2)

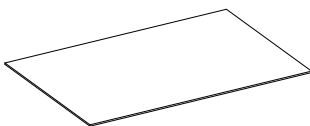

H6 - Panneau inférieur du tiroir
(Qté. 2)

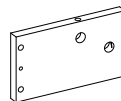

I- Panneau avant gauche du bureau
(Qté. 1)

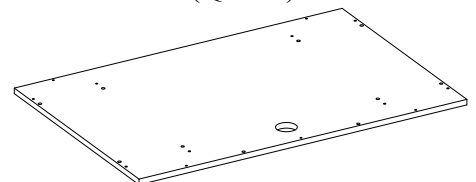

J- Panneau supérieur du retour de bureau
(Qté. 1)

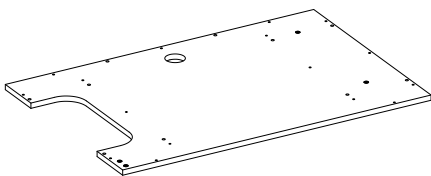

K- Panneau inférieur du retour de bureau
(Qté. 1)

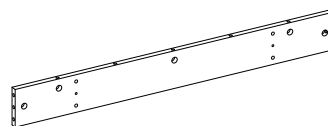

L- Panneau arrière du retour de bureau
(Qté. 1)

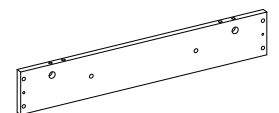

M- Côté gauche du retour de bureau
(Qté. 1)

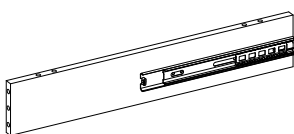

N- Panneau de séparation droit du retour
(Qté. 1)

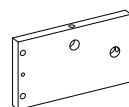

O- Avant gauche du retour
(Qté. 1)

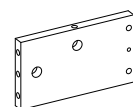

P- Avant droite du retour
(Qté. 1)

Liste des pièces et de la quincaillerie

Lire toutes les instructions et s'assurer d'avoir toutes les pièces et la quincaillerie avant de commencer le montage.

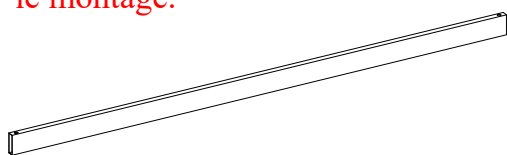

Q- Long cadre du bureau (Qté. 1)

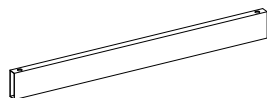

R- Court cadre de bureau (Qté. 1)

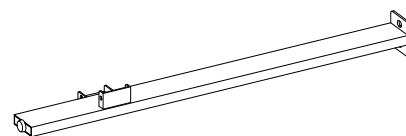

S- Pied arrière de bureau (Qté. 1)

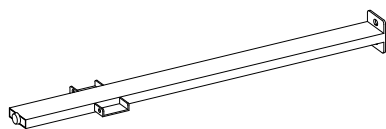

T- Pied avant de bureau (Qté. 1)

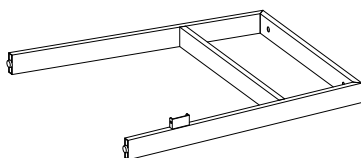

U- Cadre latéral du bureau (Qté. 1)

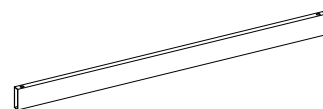

V- Cadre de retour (Qté. 1)

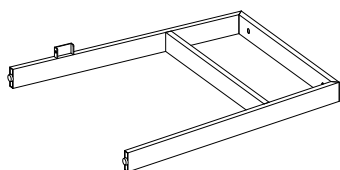

W- Cadre latéral du retour (Qté. 1)



X- Roue de câble (Qté. 3)

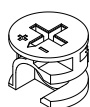

(1) Grand verrou à came
(Qté 46 + 2 extra)

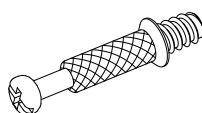

(2) Grand boulon à came
(Qté 46 + 2 extra)

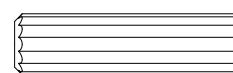

(3) Cheville en bois M8 x 30 mm
(Qté 74 + 2 extra)

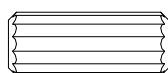

(4) Cheville en bois M8 x 20 mm
(Qté 2 + 1 extra)

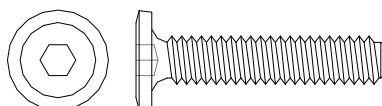

(5) Boulon de 1/4" x 30 mm
(Qté 6 + 1 extra)



(6) Rondelle de verrouillage
(Qté 14 + 1 extra)

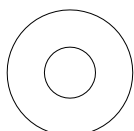

(7) Rondelle plate
(Qté 14 + 1 extra)

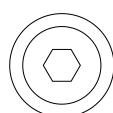

(8) Boulon de 1/4" x 18 mm
(Qté 14 + 1 extra)

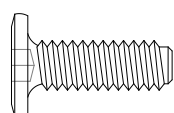

(9) Boulon de 5/32" x 12 mm
(Qté 6 + 1 extra)

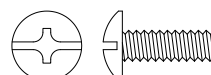

(10) Petite serrure à came
(Qté 12 + 1 extra)

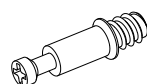

(11) Petit boulon à came
(Qté 12 + 1 extra)

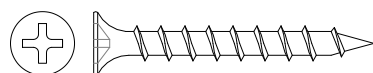

(12) Vis M4 x 35 mm
(Qté 48 + 2 extra)



(13) Vis à tête plate M4 x 14 mm
(Qté 4 + 1 extra)

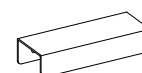

(14) Poignée
(Qté 2)



(15) OEillet (Qté. 2)

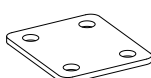

(16) Support en métal (Qté. 1)



Clé hexagonale (Qté. 1)



Colle (Qté. 2)

Outils requis : Clé hexagonale (fournie), tournevis à pointe cruciforme et marteau (non fournis).

Assemblage du tiroir

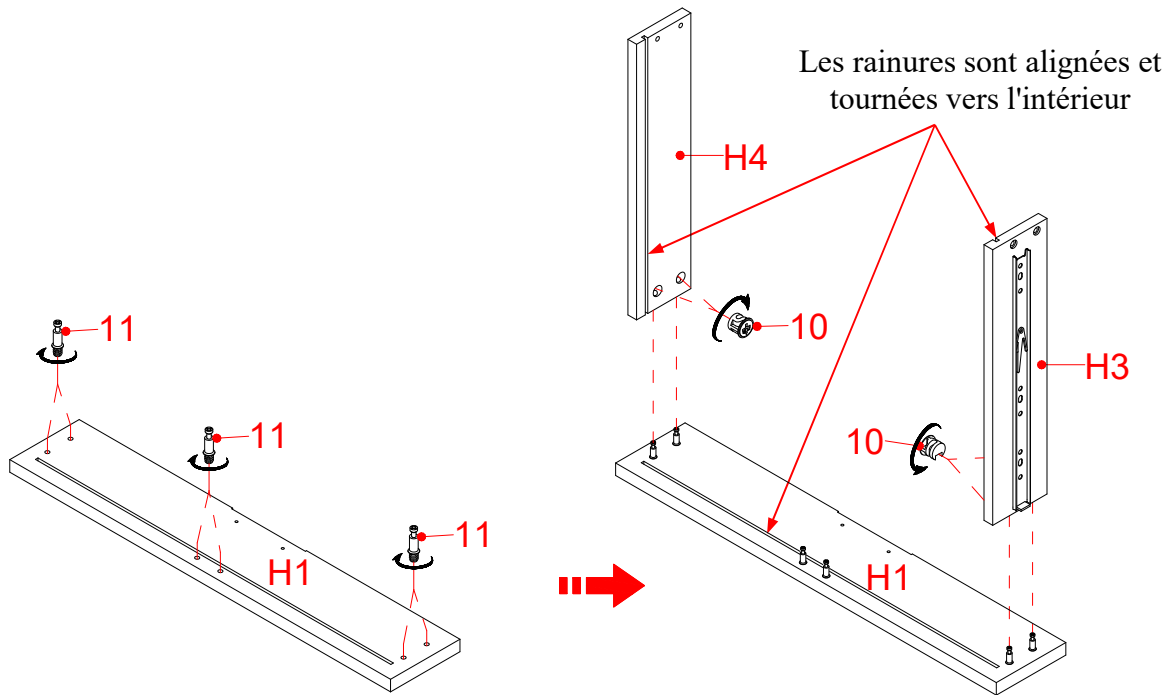

1. Déballez l'unité et assurez-vous que vous avez tout le matériel et les pièces nécessaires. Assemblez l'unité sur un sol moquette ou sur le carton vide pour éviter les rayures.
2. Vissez fermement les petites boulons à came (11) dans les petits trous prévus à cet effet sur le devant du tiroir (H1) à l'aide d'un tournevis cruciforme.
3. Fixez les côtés gauche et droit du tiroir (H3 et H4) au devant du tiroir (H1) à l'aide de 4 petites serrures à came (10).

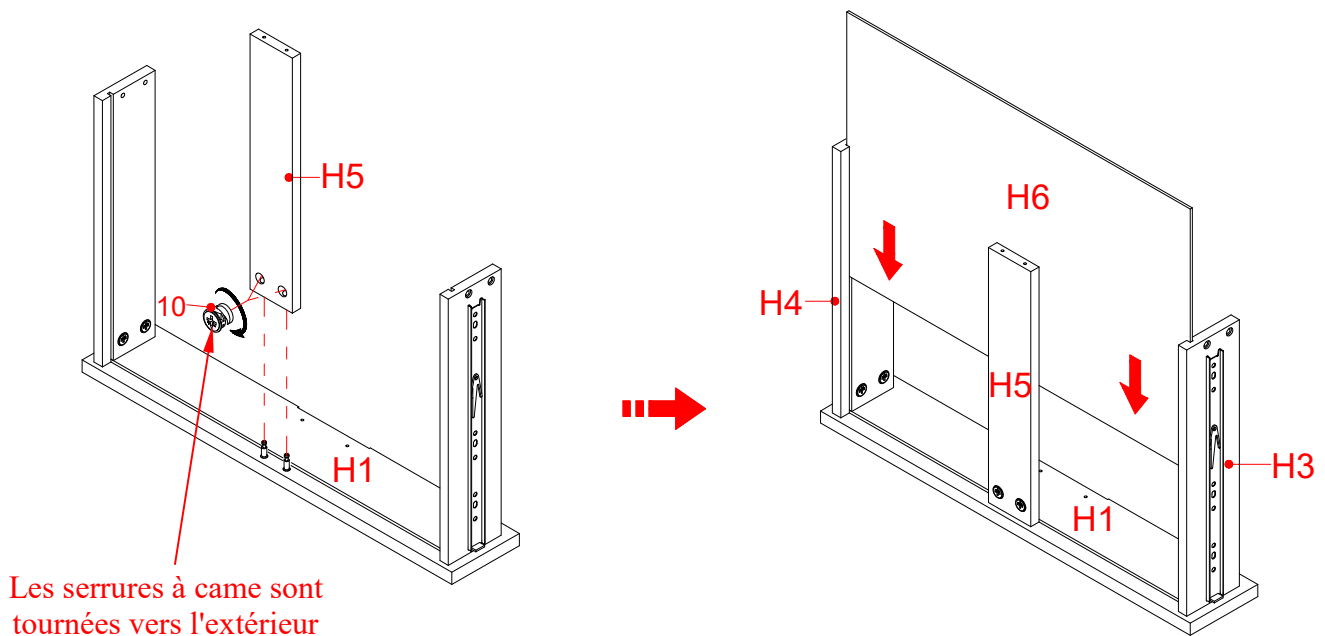

4. Fixez le support inférieur du tiroir (H5) au devant du tiroir (H1) avec 2 petites serrures à came (10).
5. Faites glisser le panneau inférieur du tiroir (H6) à fond dans les rainures.

Assemblage du tiroir

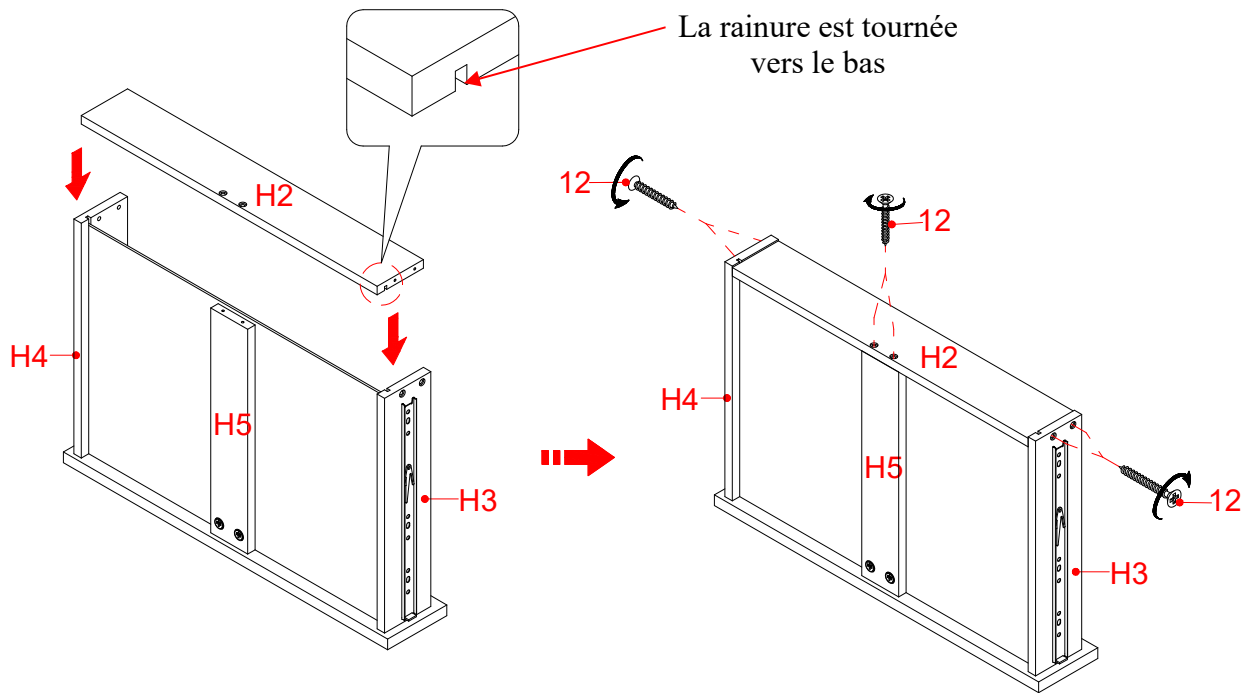

- Fixez le panneau arrière du tiroir (H2) aux panneaux latéraux du tiroir (H3 et H4) et au support inférieur (H5) à l'aide de six vis de 35 mm (12). Assurez-vous que le panneau inférieur du tiroir (H6) s'insère bien dans la rainure du panneau arrière du tiroir (H2).

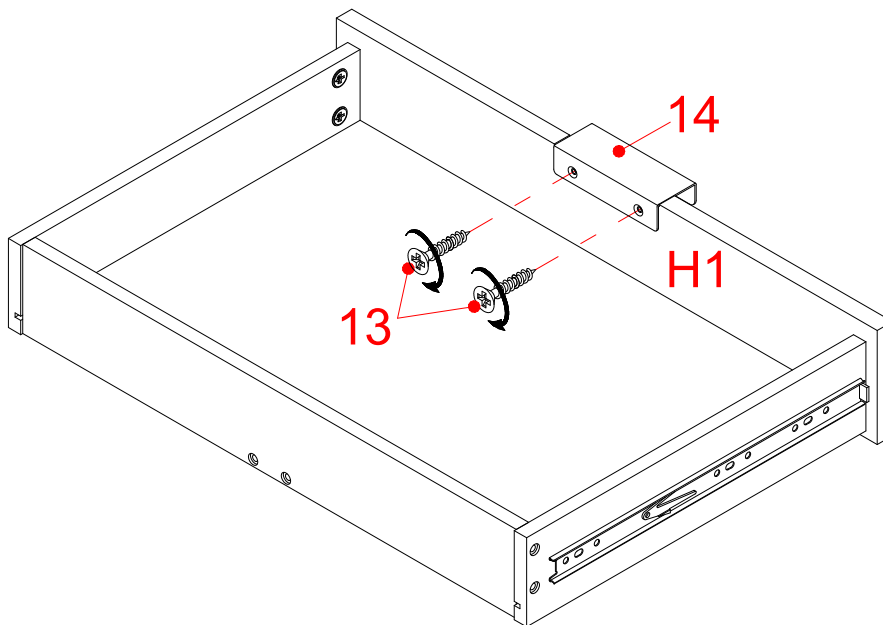

- Redressez le tiroir assemblé. Fixez la poignée (14) aux trous avants du tiroir (H1) à l'aide de deux vis à tête plate de 14 mm (13).
- Répétez la même procédure pour assembler l'autre tiroir.

Assemblage de bureau

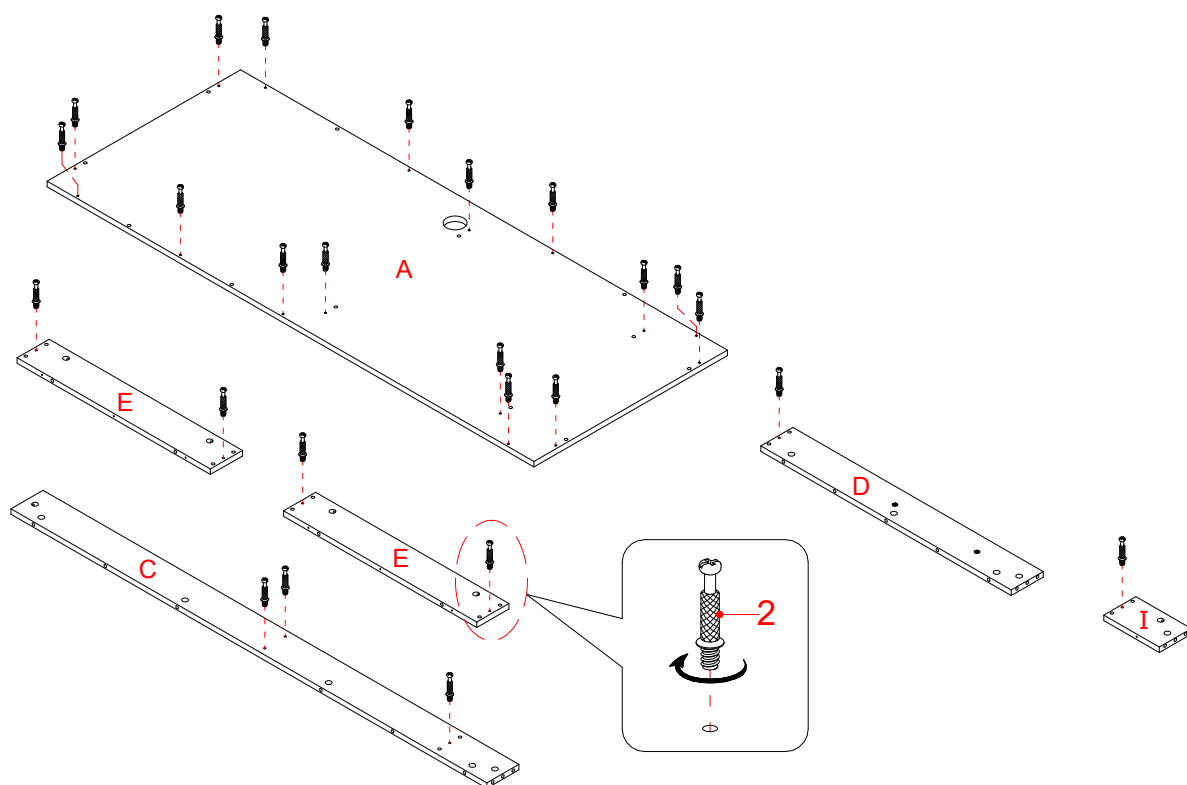

9. Vissez fermement les gros boulons à came (2) dans les petits trous prévus à cet effet sur le panneau supérieur du bureau (A), le panneau arrière (C), les panneaux latéraux (E) et les panneaux avant (D et I) à l'aide d'un tournevis cruciforme.

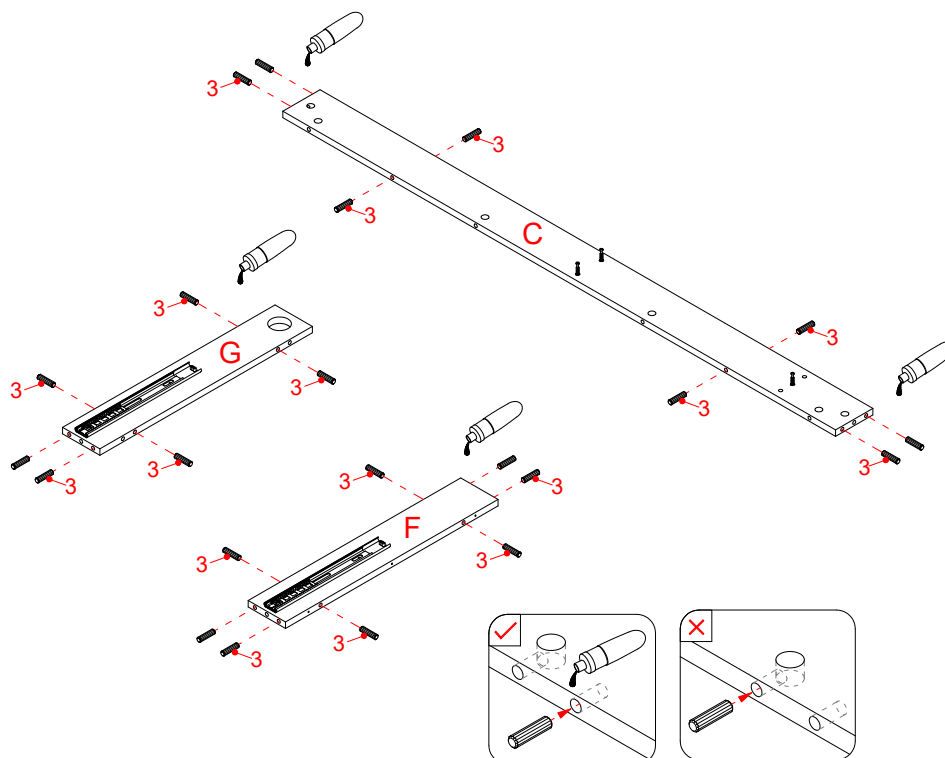

10. Collez les chevilles à bois M8 x 30 mm (3) dans les trous intérieurs du panneau arrière (C) et des panneaux de séparation (F et G).

REMARQUE : Il est très important d'utiliser une petite quantité de colle aux deux extrémités des goujons.

Assemblage de bureau

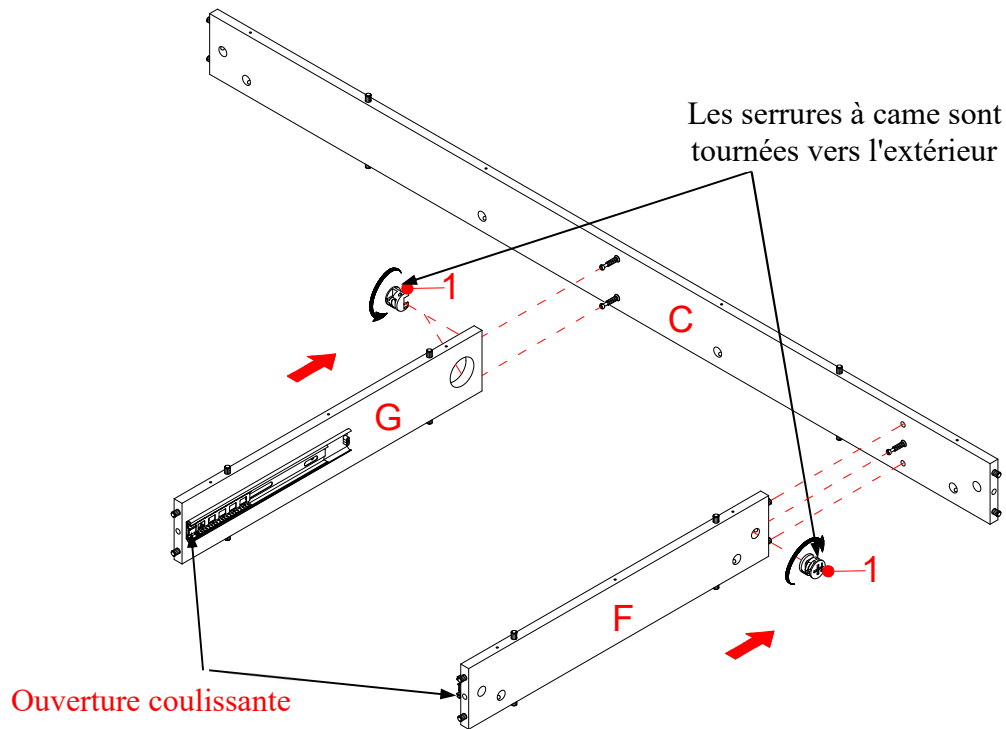

- Alignez et fixez les panneaux de partition (F et G) au panneau arrière (C) en engageant 3 grands verrous à came (1) (reportez-vous à la page 3 de l'annexe sur le fonctionnement du système de verrouillage à came).

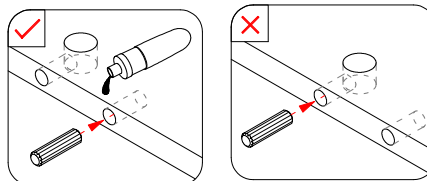
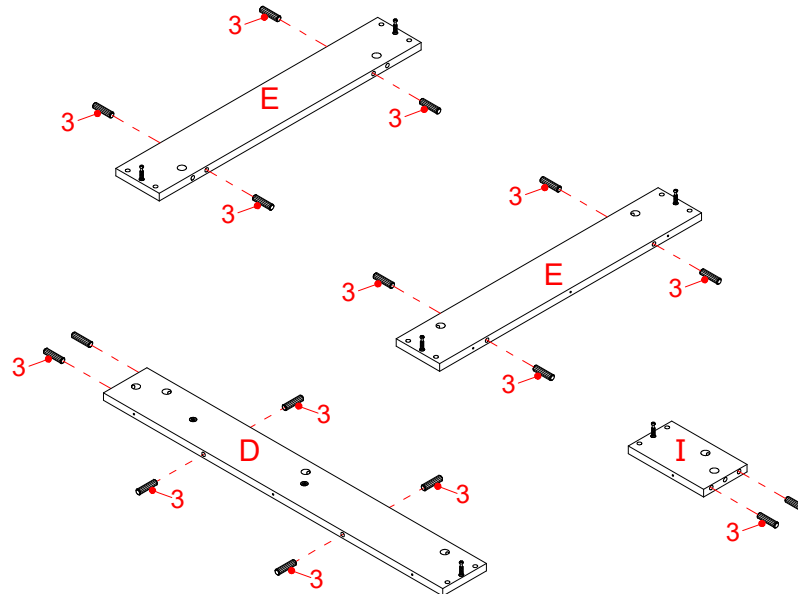

- Collez des chevilles en bois M8 x 30 mm (3) dans les trous intérieurs des panneaux latéraux (E) et des panneaux avant (D et I).

Assemblage de bureau

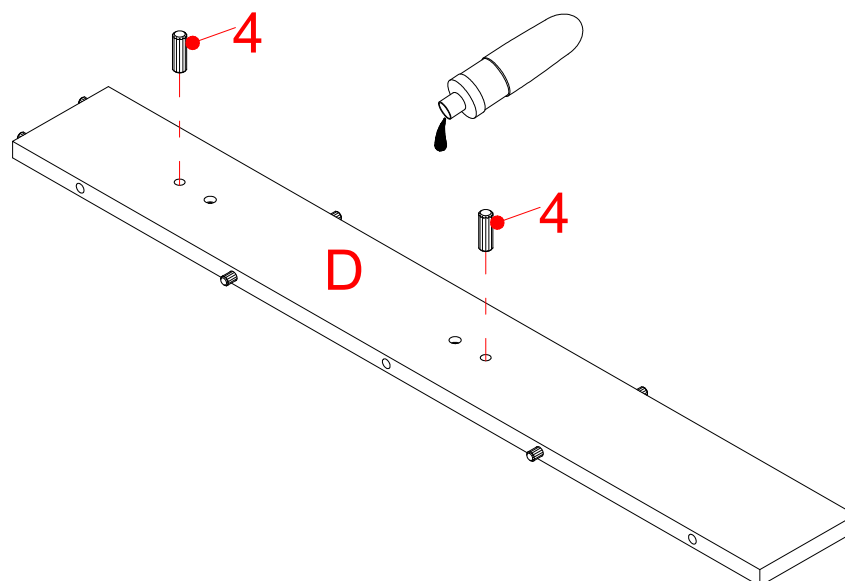

13. Collez les chevilles à bois M8 x 20 mm (4) dans les trous intérieurs du panneau avant droit du bureau (D).

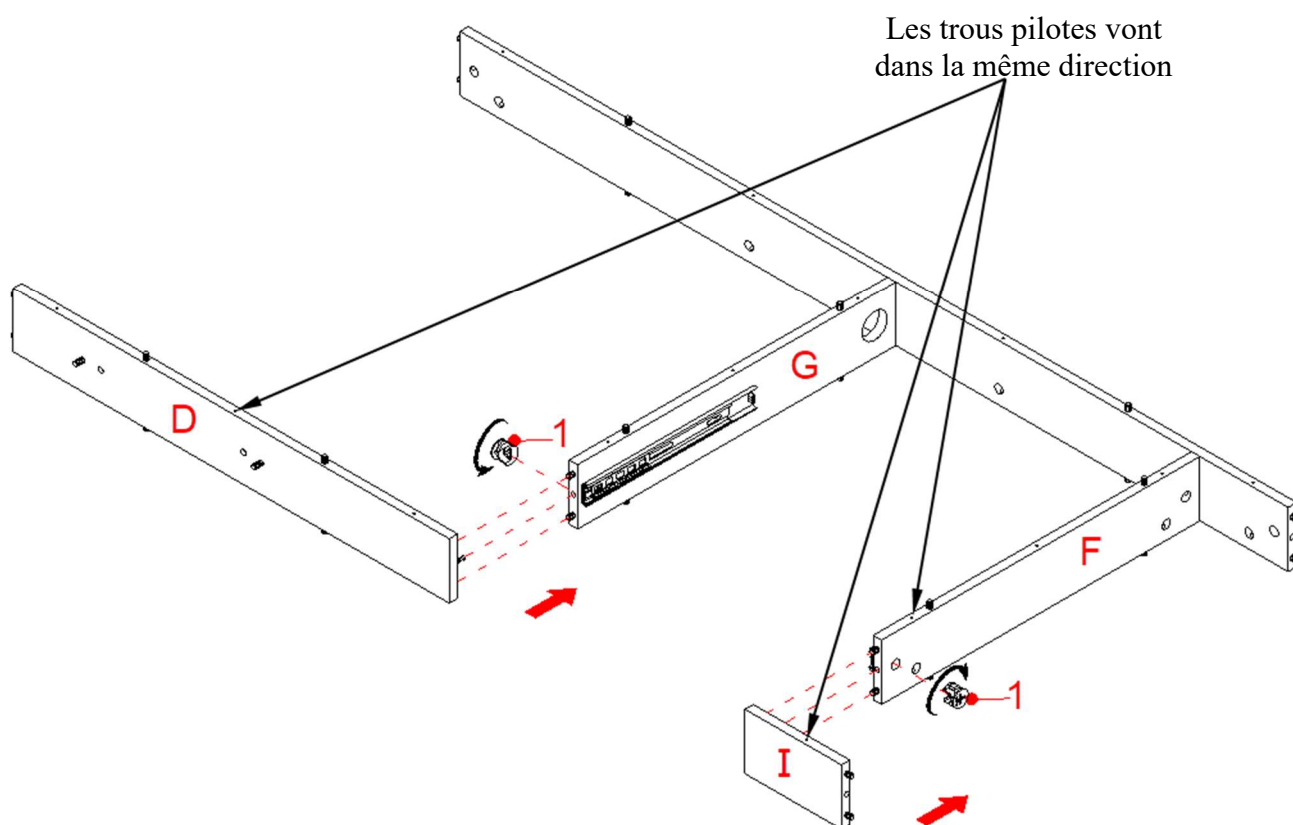

14. Fixez le panneau avant droit du bureau (D) au panneau de séparation droit (G) avec un grand verrou à came (1).
15. Fixez le panneau avant gauche du bureau (I) au panneau de séparation gauche (F) avec un grand verrou à came (1).

Assemblage de bureau

Les trous pilotes vont dans la même direction

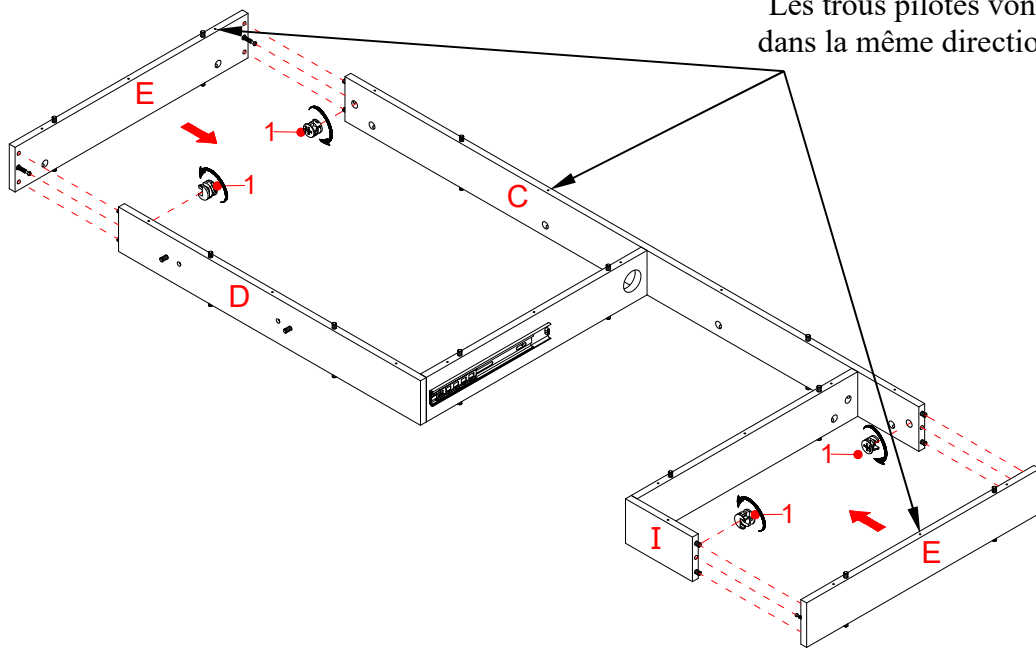

16. Alignez et fixez les panneaux latéraux du bureau (E) aux deux côtés en engageant 4 grandes serrures à came (1).

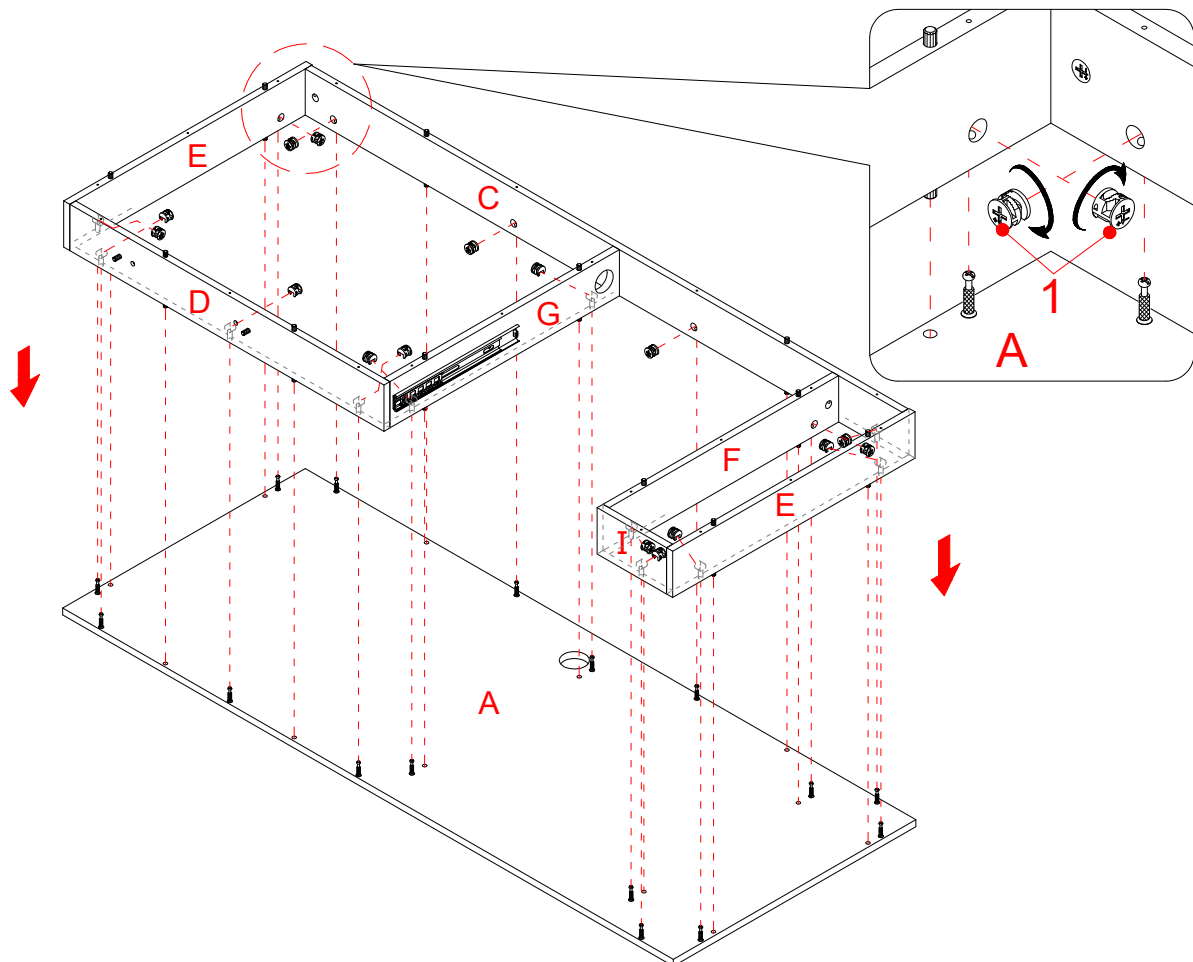

17. Alignez et fixez l'assemblage précédent au panneau supérieur du bureau (A) en engageant 16 grands verrous à came (1).

Assemblage de bureau

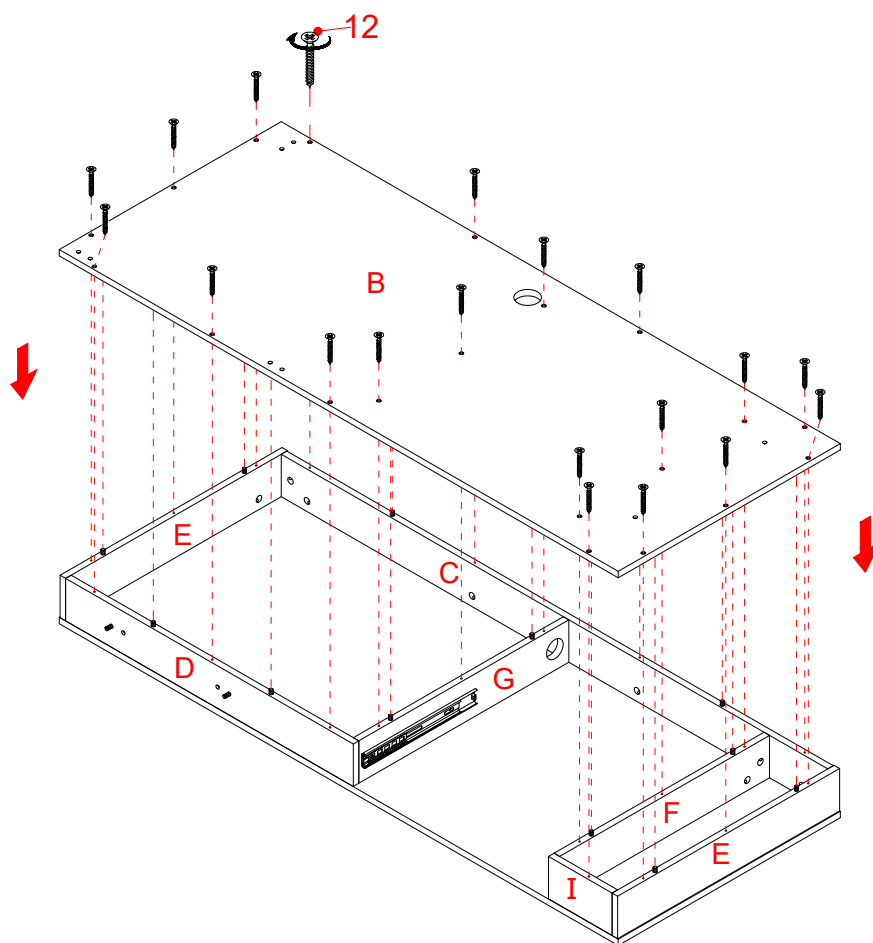

18. Fixez le panneau inférieur du bureau (B) à l'assemblage précédent à l'aide des vis de 35 mm (12).

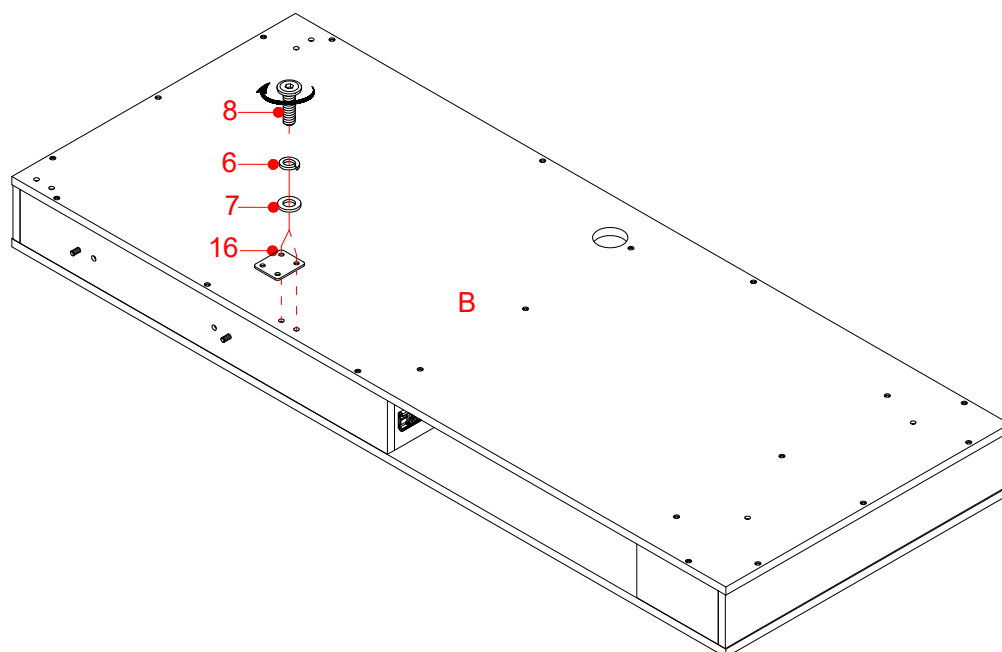

19. Fixez le support en métal (16) au panneau inférieur du bureau (B) à l'aide de deux boulons de 18 mm (8) et de deux rondelles (6 et 7).

Assemblage de bureau

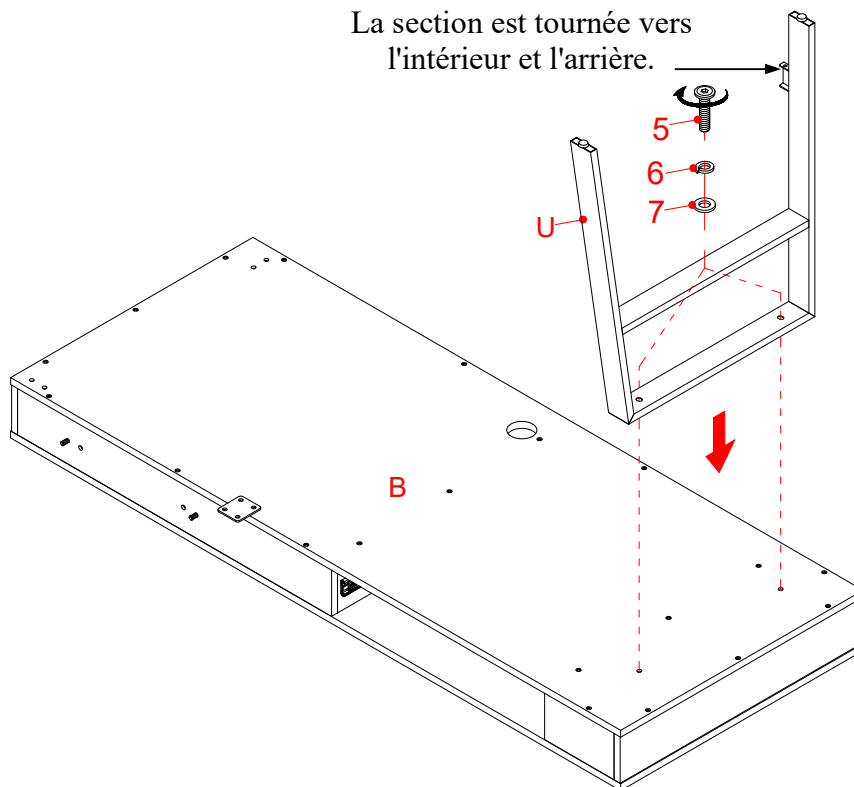

20. Fixez le cadre latéral du bureau (U) au panneau inférieur (B) à l'aide de deux boulons de 30 mm (5) et de deux rondelles (6 et 7).

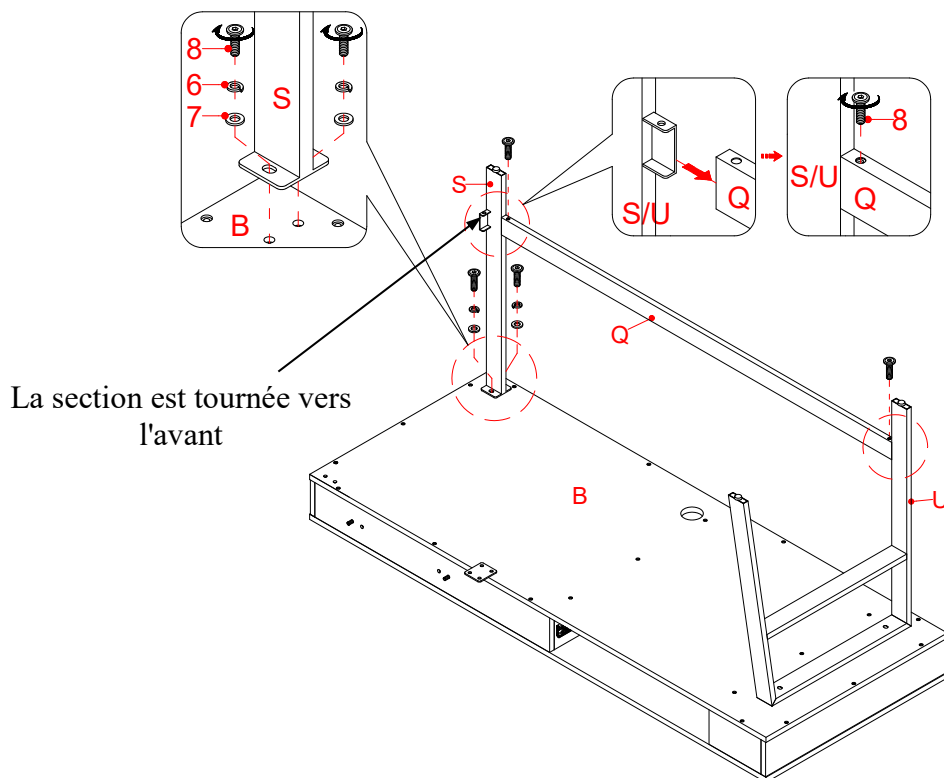

21. Fixez le long cadre du bureau (Q) entre le cadre latéral du bureau (U) et le pied arrière du bureau (S) à l'aide de deux boulons de 18 mm (8).
22. Fixez le pied arrière du bureau (S) au panneau inférieur du bureau (B) à l'aide de deux boulons de 18 mm (8) et de deux rondelles (6 et 7).

Assemblage de bureau

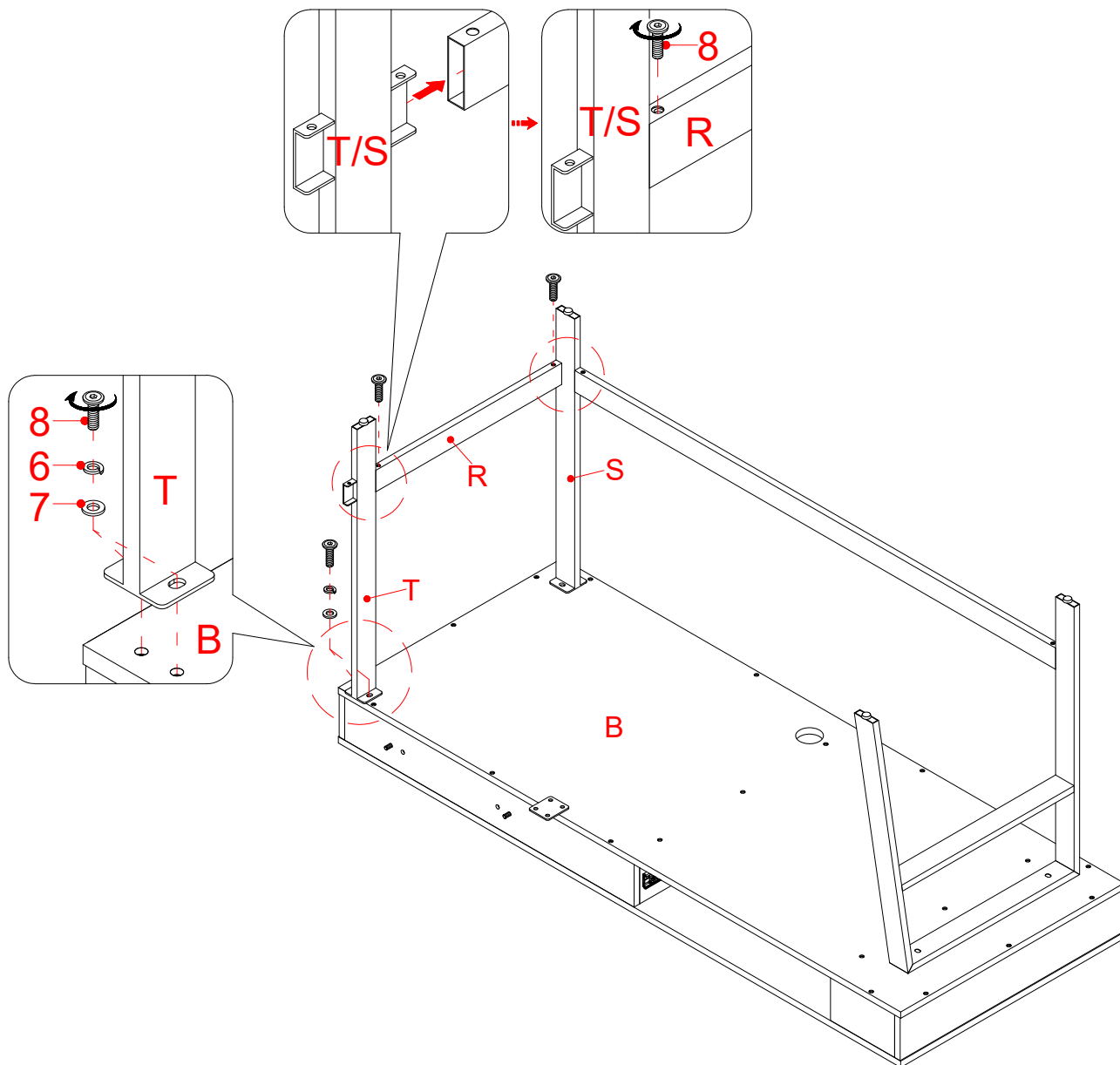

23. Fixez le cadre court du bureau (R) entre les pieds avant et arrière du bureau (T et S) à l'aide de deux boulons de 18 mm (8).
24. Fixez le pied avant du bureau (T) au panneau inférieur du bureau (B) à l'aide de deux boulons de 18 mm (8) et de deux rondelles (6 et 7).

Assemblage du retour de bureau

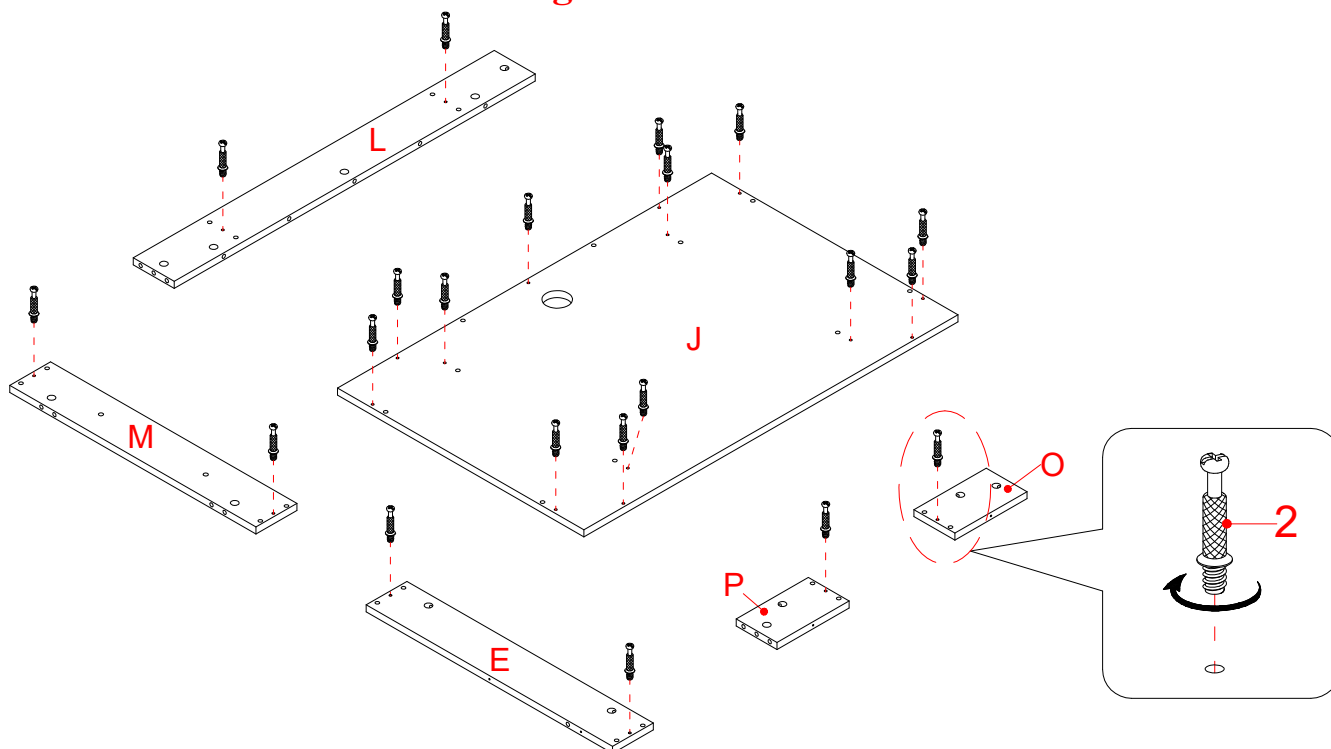

25. Vissez fermement les gros boulons à came (2) dans les petits trous prévus à cet effet sur le panneau supérieur du retour (J), le panneau arrière du retour (L), le panneau latéral gauche du retour (M), le panneau latéral de bureau (E) et les panneaux avant (O et P) à l'aide d'un tournevis cruciforme.

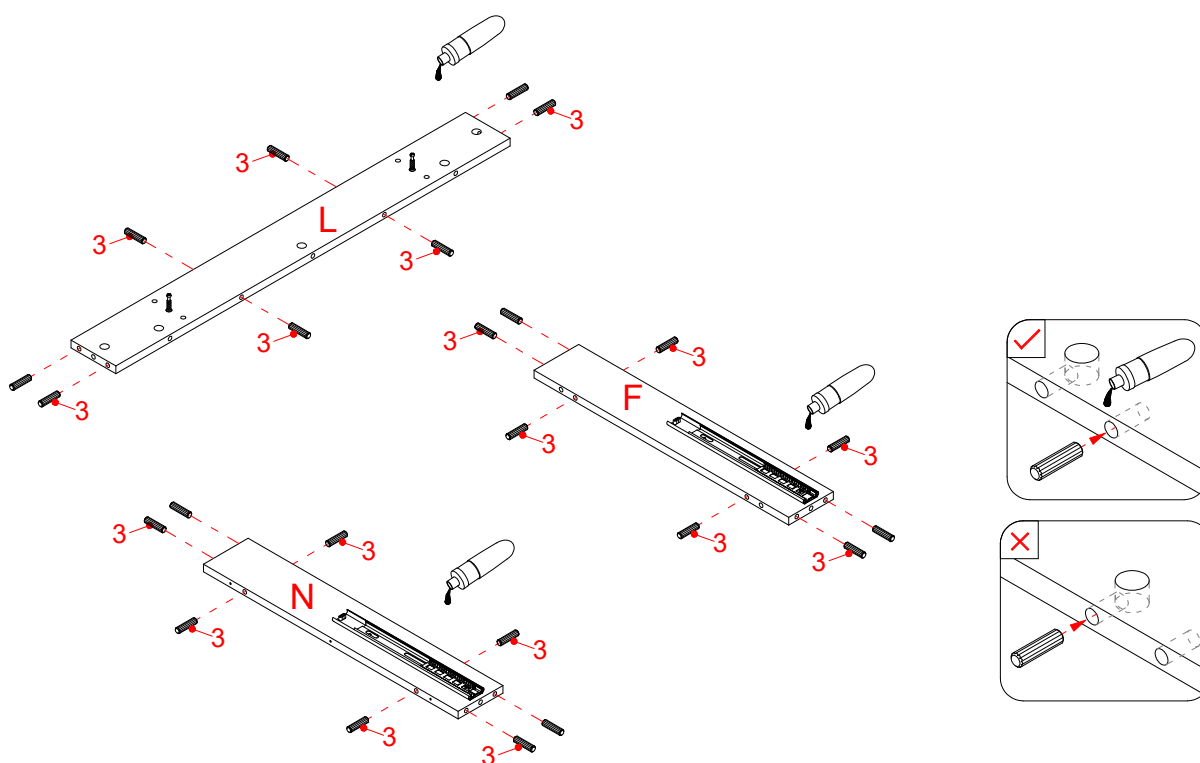

26. Collez les chevilles à bois M8 x 30 mm (3) dans les trous intérieurs du panneau arrière (L) et des panneaux de séparation (F et N).

REMARQUE : Il est très important d'utiliser une petite quantité de colle aux deux extrémités des goujons.

Assemblage du retour de bureau

Les serrures à came sont tournées vers l'extérieur

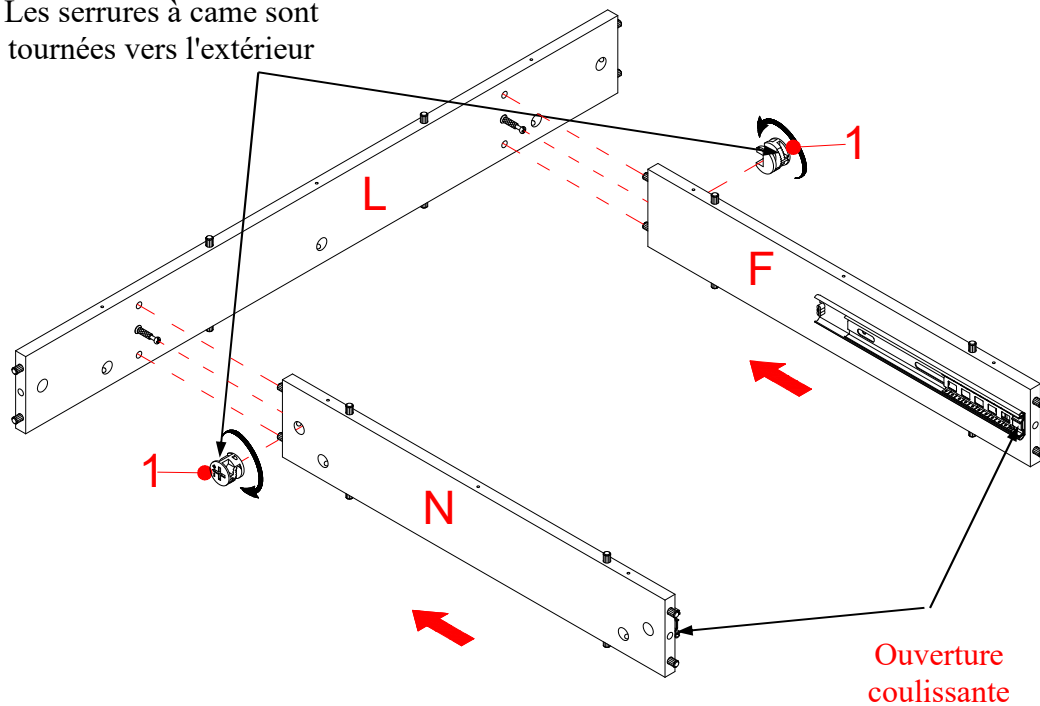

27. Alignez et fixez les panneaux de séparation (F et N) au panneau arrière (L) en engageant 2 grands verrous à came (1) (reportez-vous à la page 3 de l'annexe sur le fonctionnement du système de verrouillage à came).

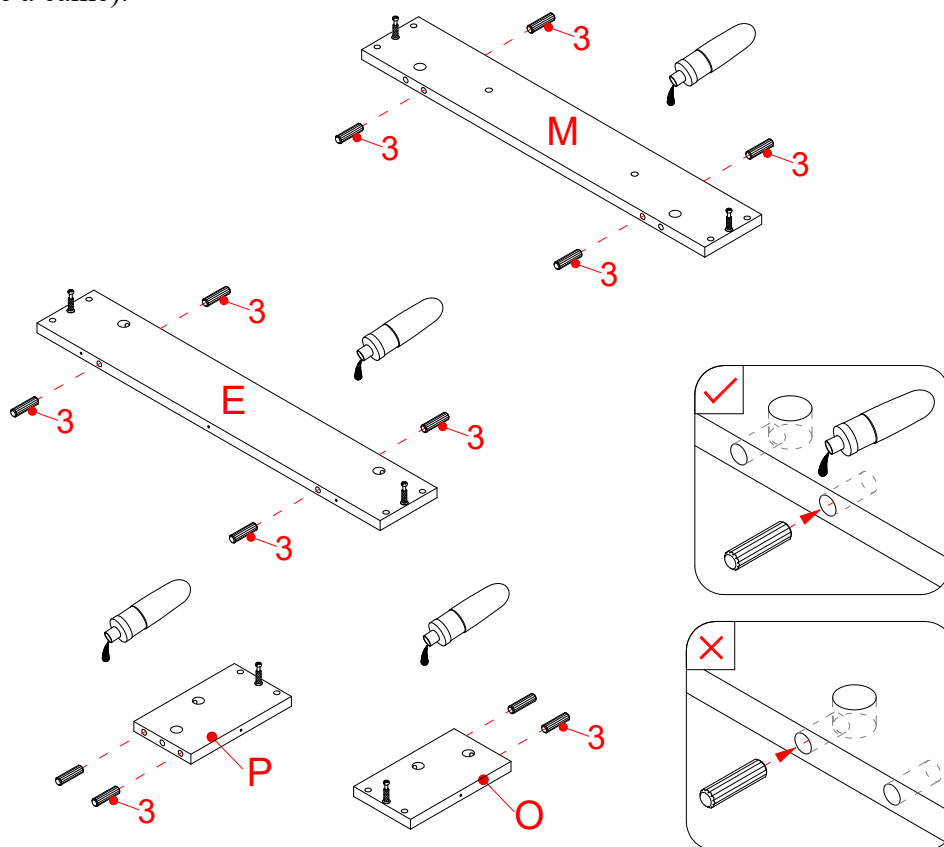

28. Collez des chevilles en bois M8 x 30 mm (3) dans les trous intérieurs des panneaux latéraux (E et M) et des panneaux avant (O et P).

Assemblage du retour de bureau

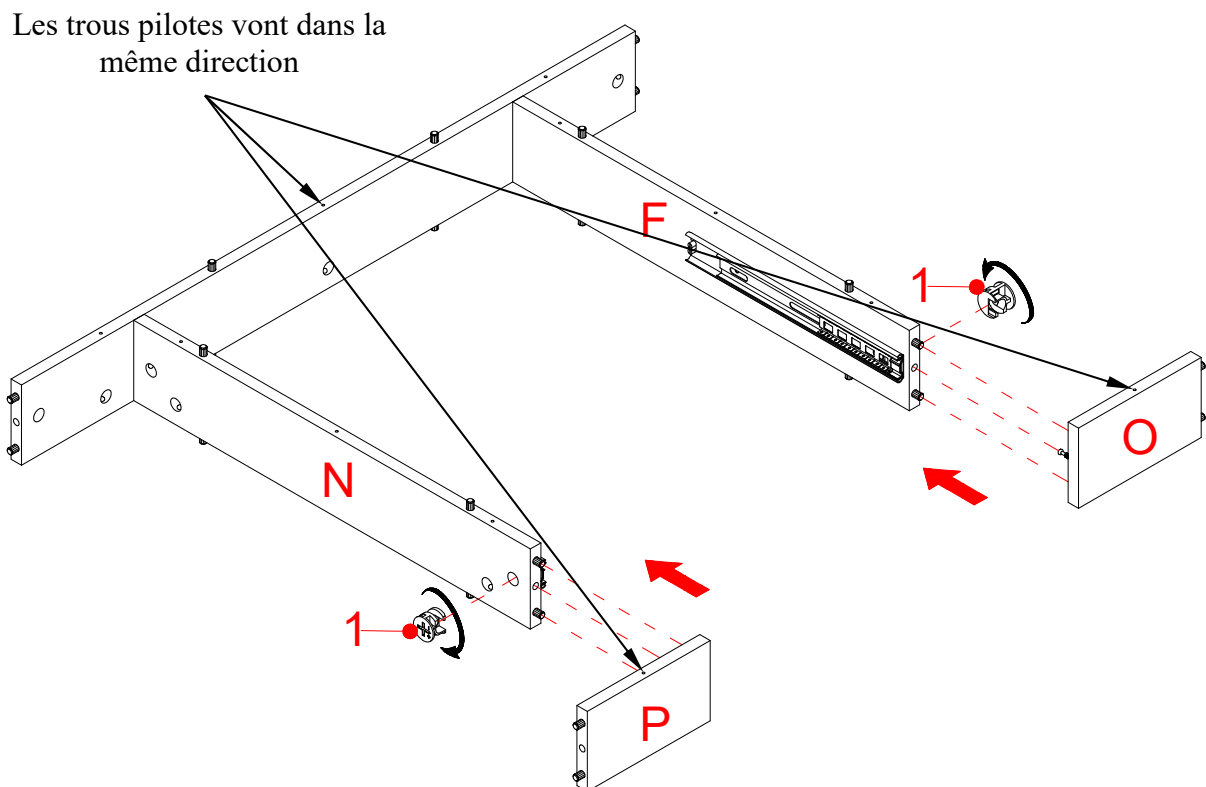

29. Fixez le panneau avant droit du bureau (P) au panneau de séparation droit (N) avec un grand verrou à came (1).
30. Fixez le panneau avant gauche du bureau (O) au panneau de séparation gauche (F) avec un grand verrou à came (1).

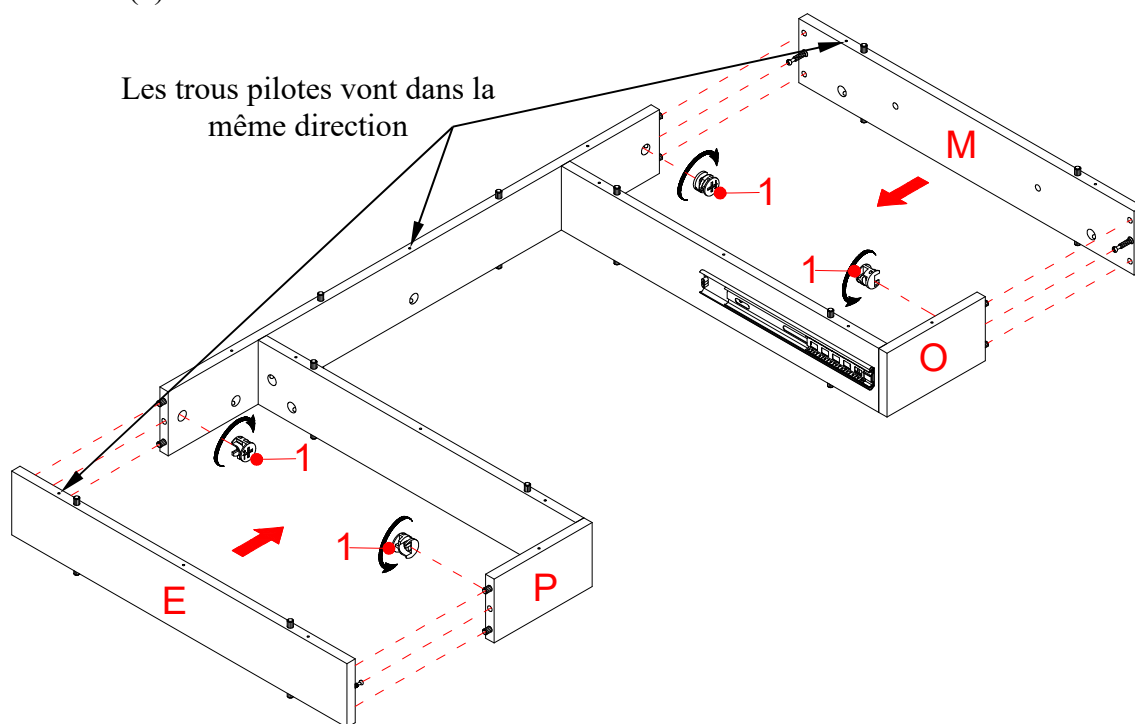

31. Fixez le panneau latéral de bureau (E) au panneau avant droit de retour (P) et au panneau arrière (L) en engageant 2 grandes serrures à came (1).
32. Fixez le côté gauche de retour (M) au panneau avant gauche (O) et au panneau arrière (L) en engageant 2 grandes serrures à came (1).

Assemblage du retour de bureau

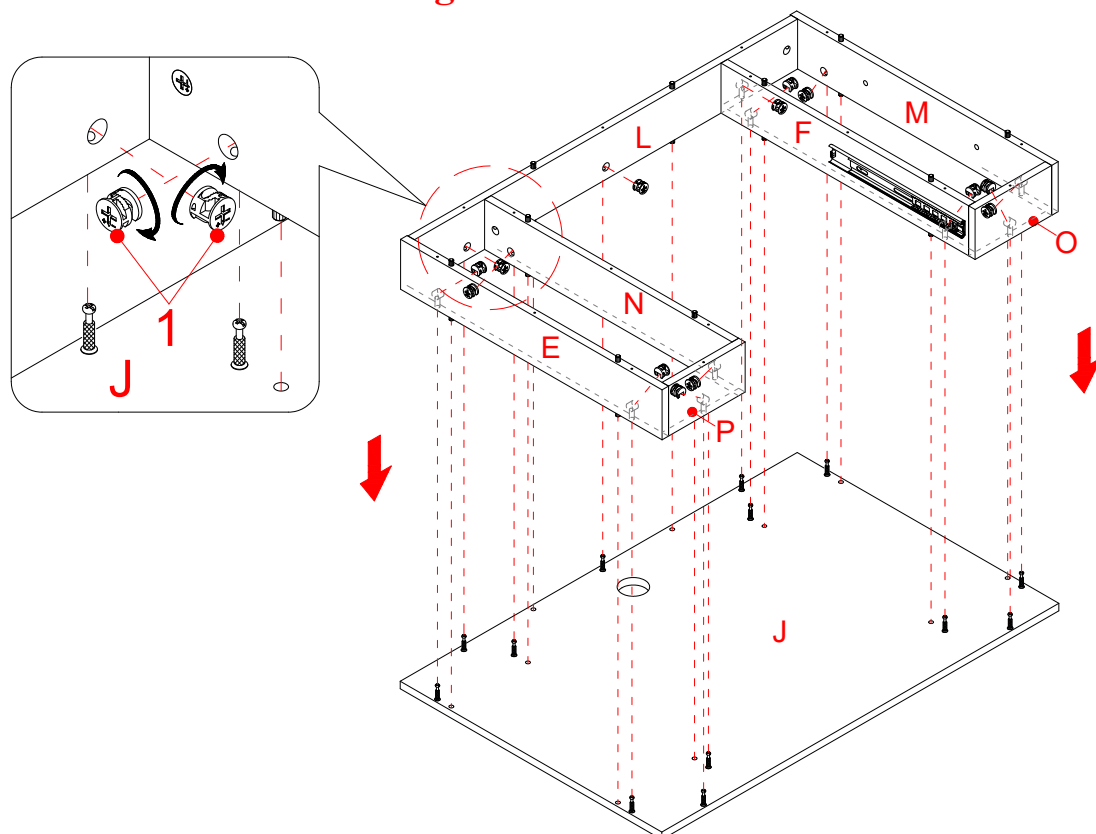

33. Aligned et fixez l'assemblage précédent au panneau supérieur du bureau (J) en engageant 13 grands verrous à came (1).

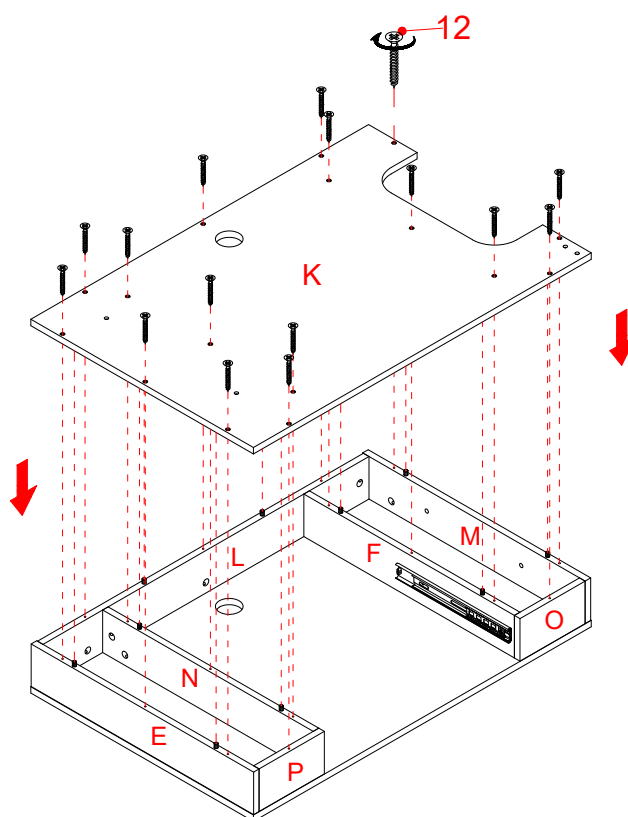

34. Fixez le panneau inférieur du bureau (K) à l'assemblage précédent à l'aide des vis de 35 mm (12).

Assemblage du retour de bureau

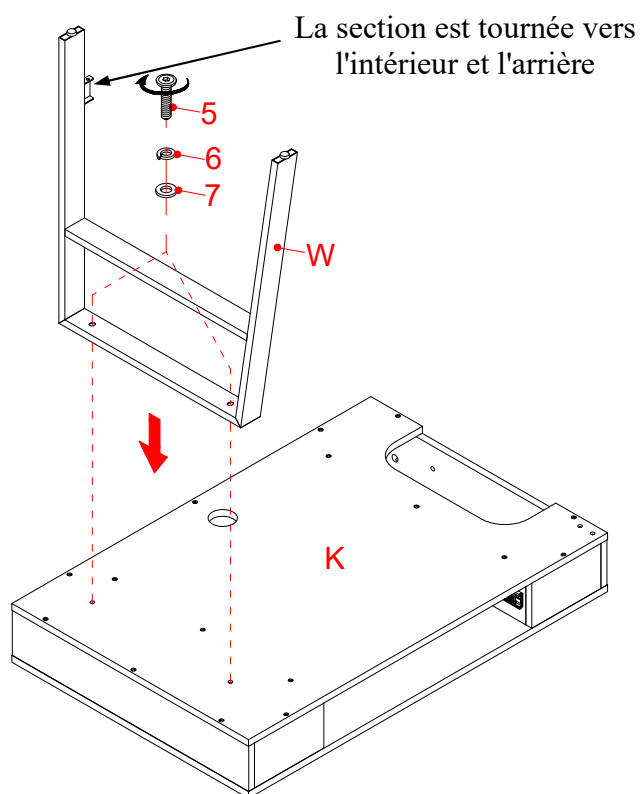

35. Fixez le cadre latéral du bureau (W) au panneau inférieur (K) à l'aide de deux boulons de 30 mm (5) et de deux rondelles (6 et 7).

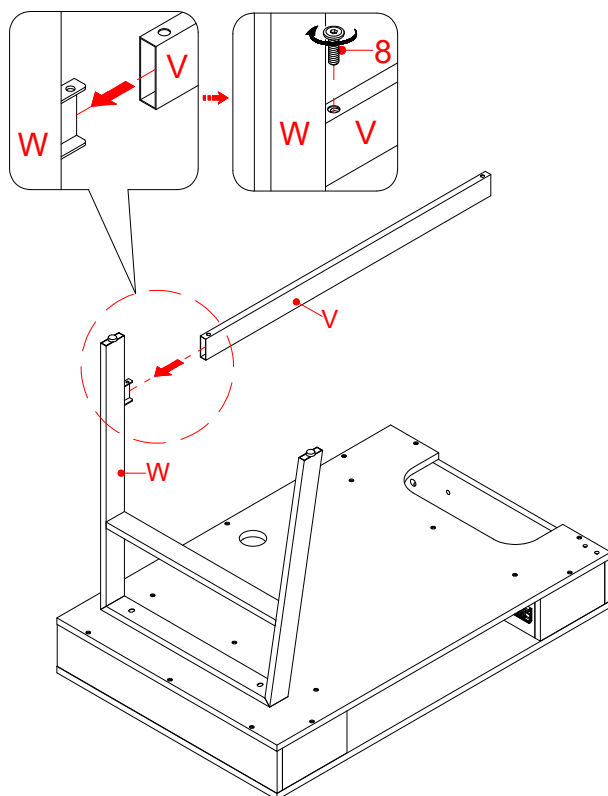

36. Attachez le cadre du retour (V) au cadre latéral (W) avec un boulon de 18 mm (8).

Instructions d'assemblage

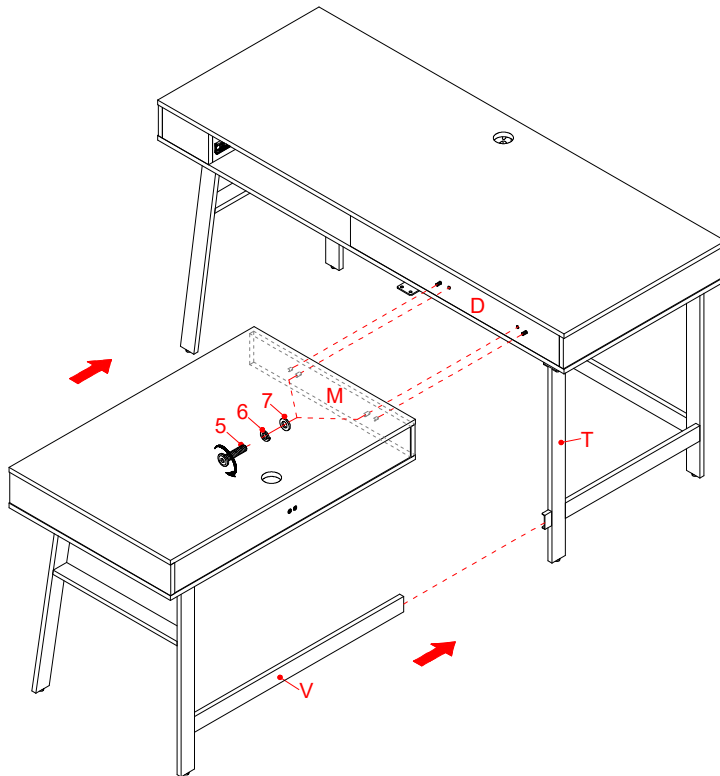

37. Demandez de l'aide pour redresser les bureaux assemblés et les positionner près du lieu d'installation final.
38. Alignez et fixez le retour assemblé au bureau avec deux boulons de 30 mm (5) et deux rondelles (6 et 7).
39. Fixez le cadre du retour (V) au pied avant du bureau (T).

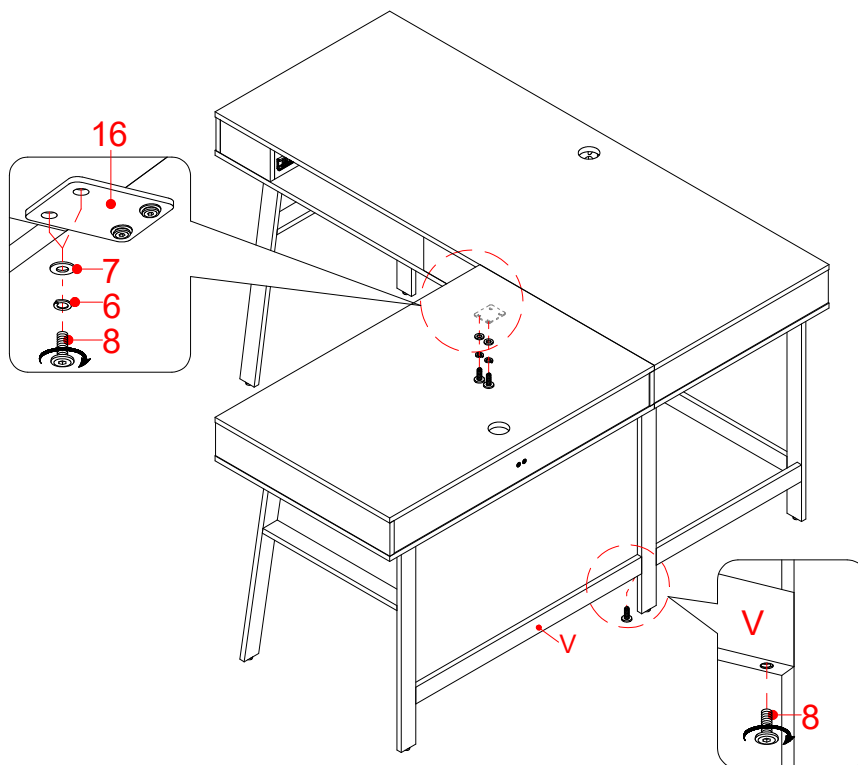

40. Fixez le support en métal (16) au panneau inférieur du bureau (K) à l'aide de deux boulons de 18 mm (8) et de deux rondelles (6 et 7).
41. Attachez le cadre du retour (V) au pied avant du bureau (T) avec un boulon de 18 mm (8).

Instructions d'assemblage

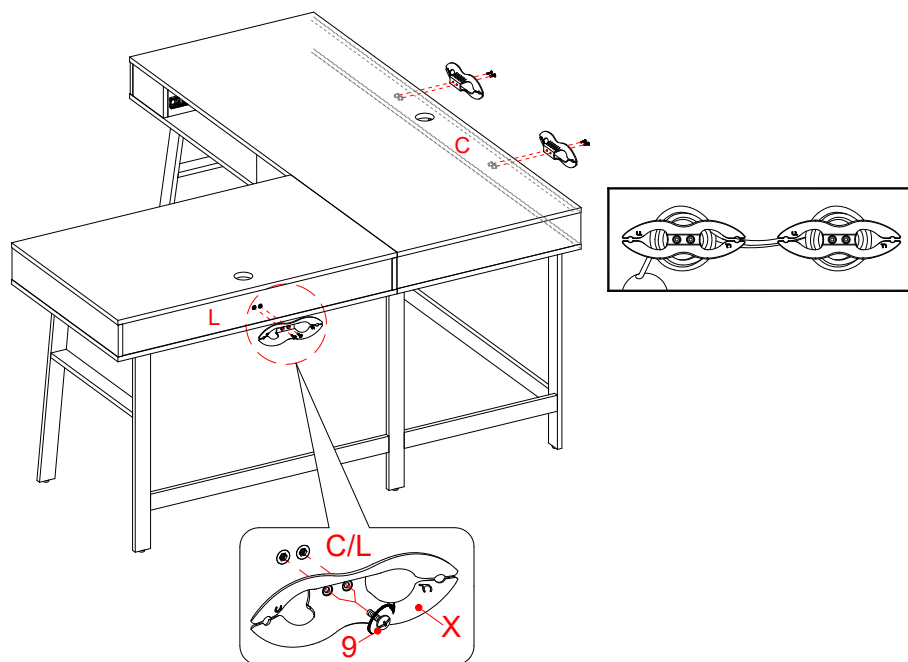

42. Fixez 2 roulettes de câble (X) aux panneaux arrière (C et L) à l'aide des boulons de 12 mm (9).

REMARQUE : vous pouvez utiliser les roulettes de câbles pour organiser les câbles et les cordons de votre centre de divertissement.

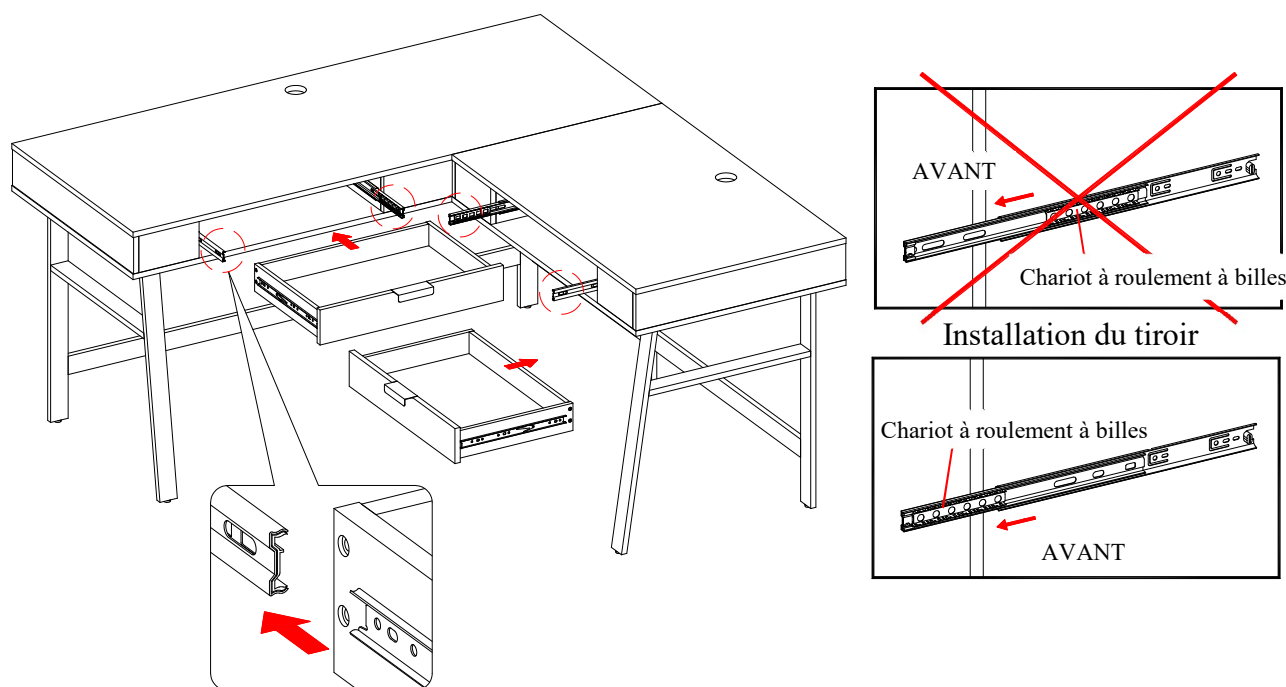

43. Insérez les tiroirs assemblés dans le cadre. Pour insérer les tiroirs assemblés dans votre unité, déployez les rails de glissière à roulement à billes sur les panneaux de séparation (F, G et N) au maximum (y compris le chariot à roulement à billes). Ensuite, alignez les glissières des tiroirs assemblés avec les rails et poussez délicatement le tiroir jusqu'à ce qu'il se bloque.

REMARQUE : Si le tiroir n'entre pas correctement, retirez-le et répétez l'étape. Si vous devez retirer le tiroir, tirez-le à fond, puis poussez simultanément le levier de dégagement en plastique des glissières à roulement à billes, puis retirez-le complètement.

Instructions d'assemblage

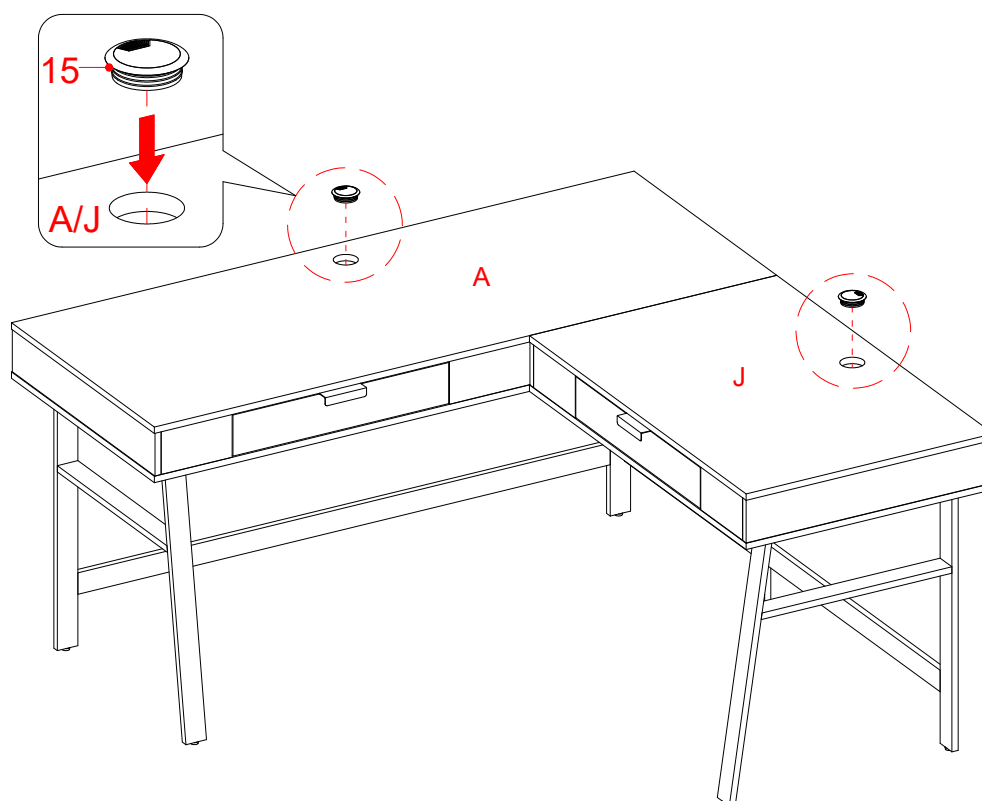

44. Insérez les œillets (15) pour couvrir les trous des panneaux supérieurs (A et J).

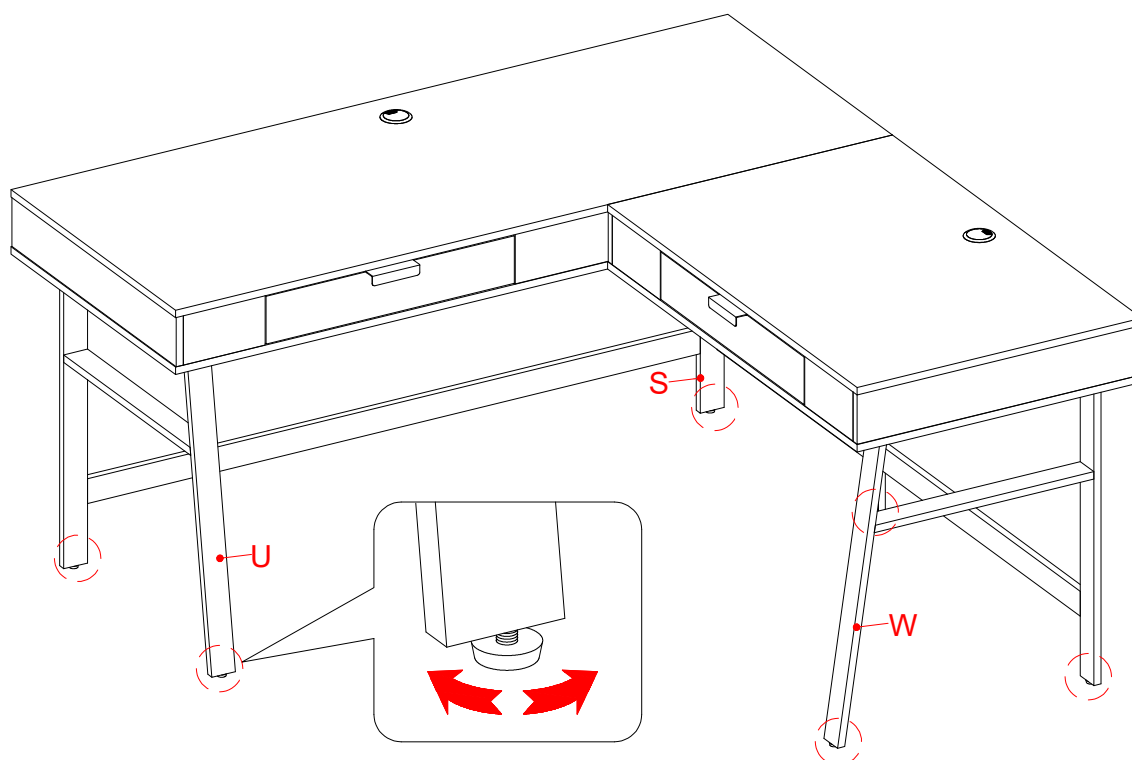

45. Si nécessaire, ajustez les niveleurs de sol pré-fixés au bas des deux pieds pour mettre l'unité à niveau.

Soin et entretien

- Utiliser un linge doux et propre qui ne rayera pas la surface lors de l'époussetage.
- L'utilisation de poli à meuble n'est pas nécessaire. Le cas échéant, tester d'abord dans un endroit non apparent.
- L'utilisation de solvant de quelque nature que ce soit sur le meuble en endommagera le fini.
- Ne jamais utiliser d'eau pour nettoyer ce meuble car cela pourrait en endommager le fini.
- Toujours utiliser des sous-verre sous les breuvages et les pots à fleur.
- Le liquide renversé devrait être essuyé sur-le-champ. Utiliser un linge doux et propre et éponger doucement le liquide. Éviter de frotter.
- Toujours utiliser des coussinets protecteurs sous les plats chauds. La chaleur peut causer une modification chimique qui tachera le fini du meuble.
- Dans le cas où le meuble serait taché ou autrement endommagé durant l'utilisation, nous recommandons de faire appel à un professionnel pour le réparer.
- Vérifier régulièrement les boulons et les vis et serrer au besoin.

Autres conseils sur l'entretien des meubles en bois

Il est préférable de garder le meuble dans un environnement contrôlé. Les écarts extrêmes de température et d'humidité pourraient décolorer, tordre, rétrécir et fendre le bois. Il est conseillé de garder le meuble éloigné du soleil direct car il pourrait en endommager le fini.

Des soins et un entretien appropriés à la maison prolongeront la durée de votre achat. Suivre les conseils importants et utiles rehaussera la beauté de votre meuble avec le temps.

Nous vous souhaitons de profiter de votre meuble durant de nombreuses années.
Merci de votre achat!

GARANTIE DE QUALITÉ

Nous sommes assurés que vous serez ravi de votre achat d'un meuble de Whalen Furniture.

Si la fabrication ou les matériaux de ce produit s'avéraient défectueux suite à une utilisation normale, nous le réparerons ou le remplacerons jusqu'à concurrence d'un (1) an après la date d'achat. Chaque produit de Whalen Furniture est conçu pour répondre aux normes les plus strictes. Nous vous garantissons d'apprécier sur-le-champ la valeur de nos meubles de qualité.

La présente garantie vous donne des droits légaux spécifiques et vous pourriez également bénéficier d'autres droits qui varient d'un état à l'autre ou d'une province à l'autre.

Service à la clientèle : 1-866-942-5362
8 h 30 à 16 h 30, heures normales du Pacifique, du lundi au vendredi
www.whalenfurniture.com



NÚMERO de LOTE: _____
FECHA de COMPRA: __/__/__

Escritorio Timbercrest

Modelo # 19WTLD-SPCA

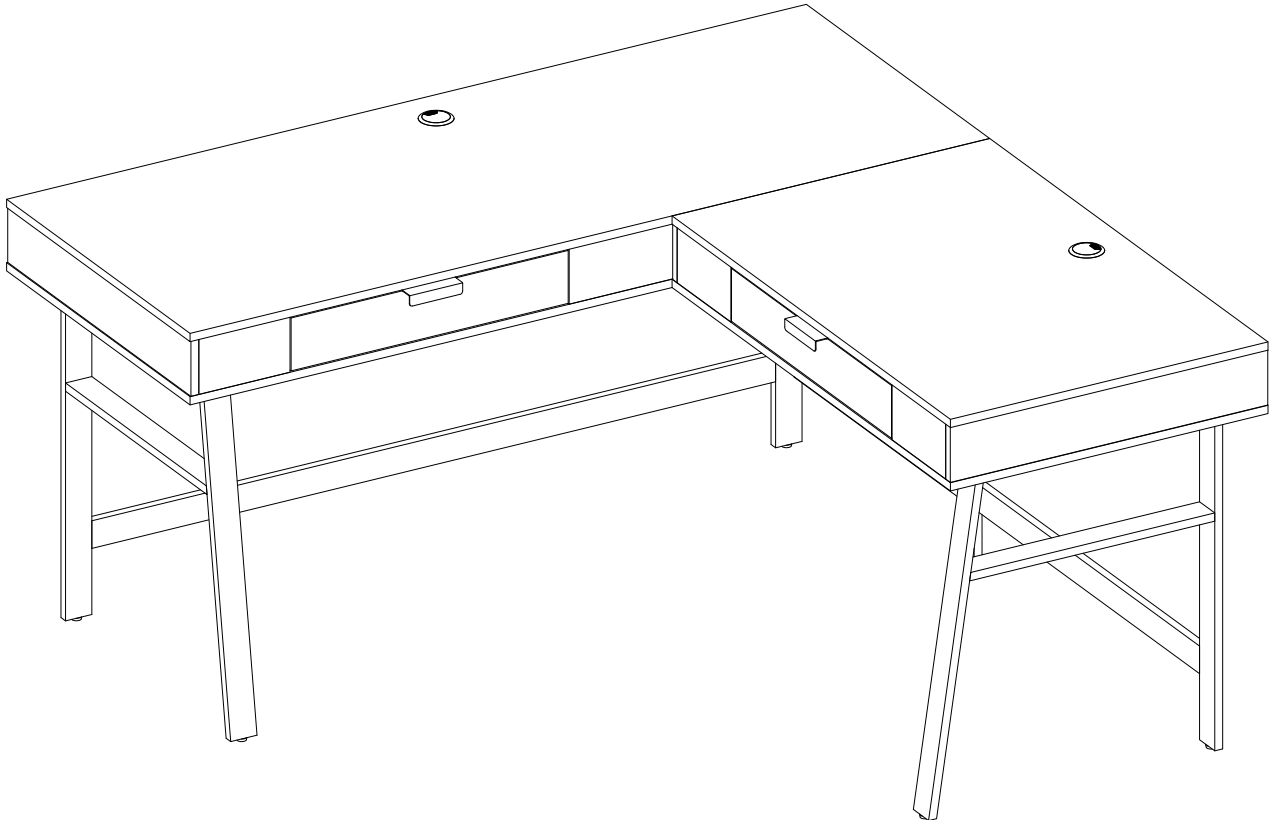

ENSAMBLE POR ADULTO REQUERIDO POR LA PRESENCIA DE PARTES PEQUEÑAS, PUNTOS FILOSOS, Y BORDES FILOSOS

Si tienen alguna pregunta acerca del ensamble o si alguna parte está faltante, no retorne este producto a la tienda donde lo compró. Por favor llame a nuestro departamento de ayuda al cliente teniendo su instructivo y lista de partes para proveer el modelo, nombre de parte o el número de fábrica:

1-866-942-5362

Hora Estándar del Pacífico: 8:30 a.m. - 4:30 p.m., de Lunes a Viernes
O visite nuestra página de Internet 24 horas al día, 7 días a la semana para asistencia

www.whalenfurniture.com

O mande un correo electrónico a **parts@whalenfurniture.com**

**ESTE INSTRUCTIVO CONTIENE INFORMACION IMPORTANTE DE SEGURIDAD.
POR FAVOR LEA Y MANTENGA PARA USO FUTURO.**

Fecha 2019-10-25

Rev. 0001-A

PESOS MÁXIMOS RECOMENDADOS

FABRICANTE: Whalen Furniture Manufacturing
CATALOGO: Escritorio Timbercrest
MODELO #: 19WTLD-SPCA
HECHO EN CHINA

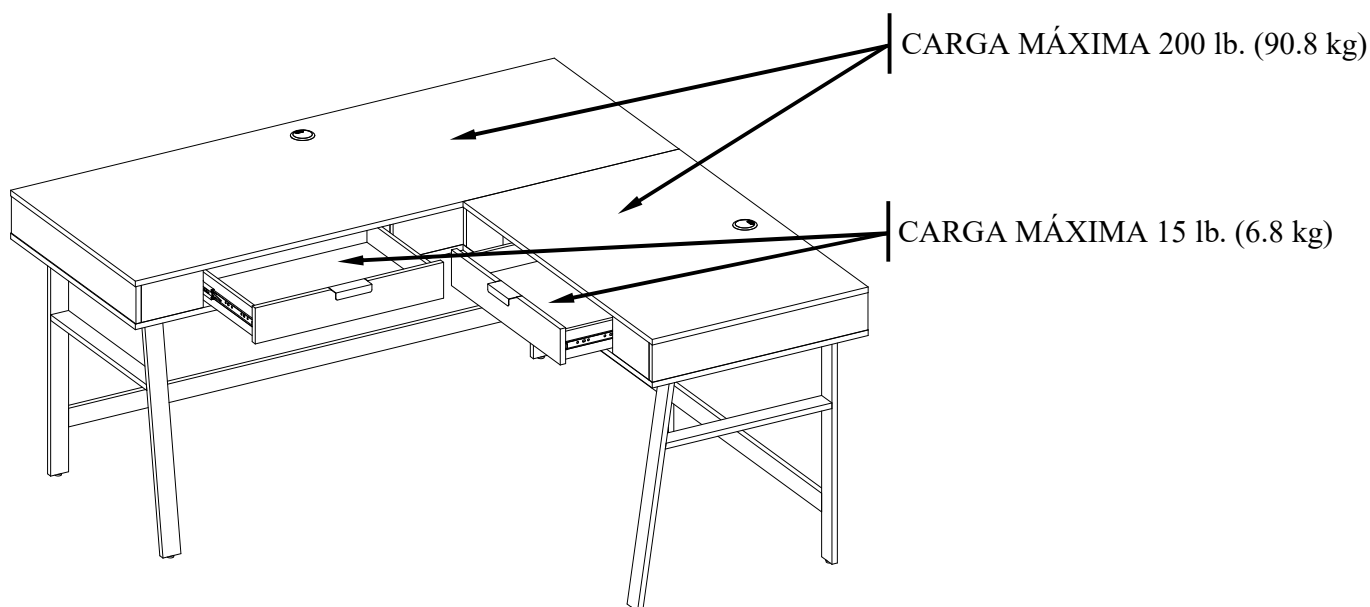

⚠ AVISO ESTA UNIDAD DEBE UTILIZARSE CON LOS PESOS MÁXIMOS INDICADOS. SI SE EXEDE EL PESO MÁXIMO, PODRIA RESULTAR EN UNA INESTABILIDAD DE LA UNIDAD CAUSANDO POSIBLES LESIONES.

NOTA

Lea atentamente toda la hoja de instrucciones antes de comenzar el montaje. Antes de deshacerse del material de empaque compruebe que no ha olvidado nada en su interior. Quite cualquier grapa u accesorio fijado al cartón antes de tirarlo. Una vez apartadas las piezas, sepárelas en grupos como se indica en la lista. Cerciórese de que tiene todas las piezas antes de comenzar el montaje. No se recomienda utilizar herramientas muy potentes para ensamblar este mueble.

IMPORTANTE

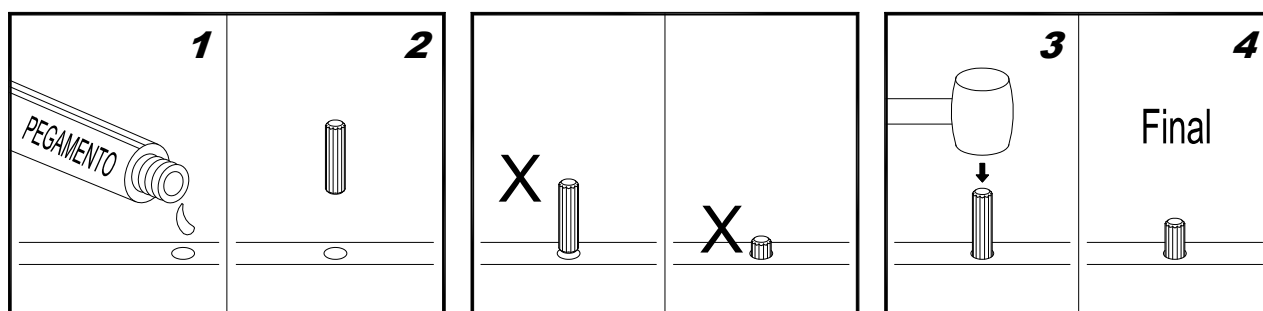

Antes de comenzar: Abra, identifique y cuente todas las partes antes del ensamble. Coloque los componentes en una superficie plana y no abrasiva. Usted necesitará las partes identificadas en la página 4 y 5 de este manual de instrucciones.

NOTA: Es muy importante utilizar pegamento con los pernos. EXCESO se pueden limpiar con un paño húmedo.

Insertar el perno al menos a mitad de camino golpeando ligeramente con un martillo de goma, si es necesario

SISTEMA TUERCA DE FIJACIÓN

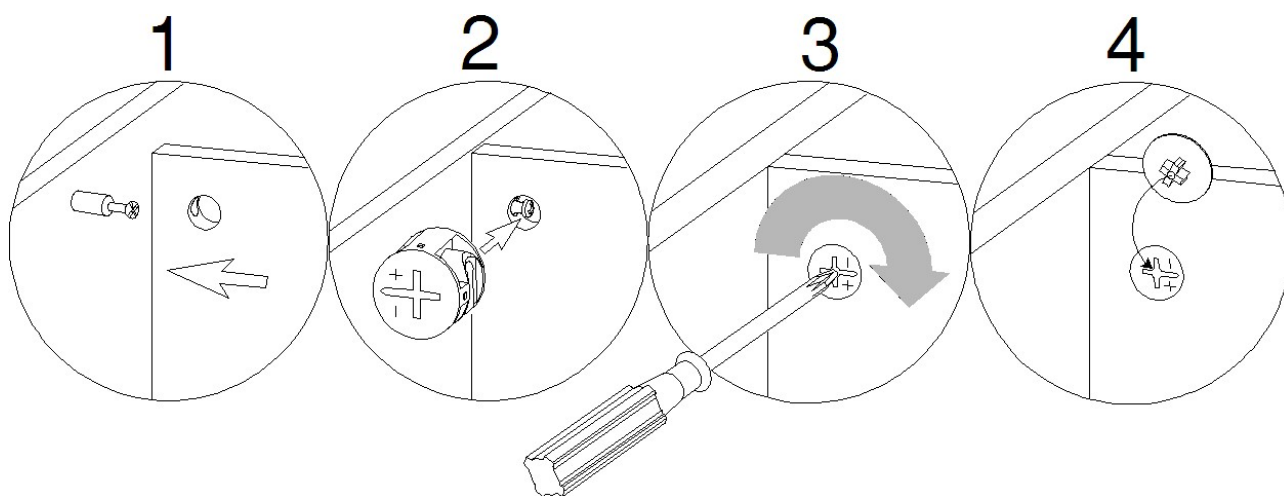

CÓMO FUNCIONA EL SISTEMA DE MONTAJE DE FIJACION

1. Fije los pernos de fijación en los insertos roscados en el panel. Conecte los dos paneles juntos; asegurándose que el perno de fijación entra en el agujero pre-perforado al final del panel para el uso de la tuerca de fijación.
2. Inserte la tuerca de fijación en el agujero grande previamente taladrado en el panel. Asegúrese de que la flecha en la cara de la tuerca se enfrenta hacia afuera y apunta hacia el perno de fijación.
3. Tome un destornillador estrella y gire la tuerca hacia la derecha para bloquear la salida del perno y asegurar en su lugar.
4. Ponga la tapa de las tuercas en la ranura transversal de la tuerca para ocultar la misma.

Ahora está listo para montar la consola para televisión.

Lista de partes y material de ferretería

Por favor lea completamente las instrucciones y verifique que estén todas las partes antes de iniciar el ensamblado.

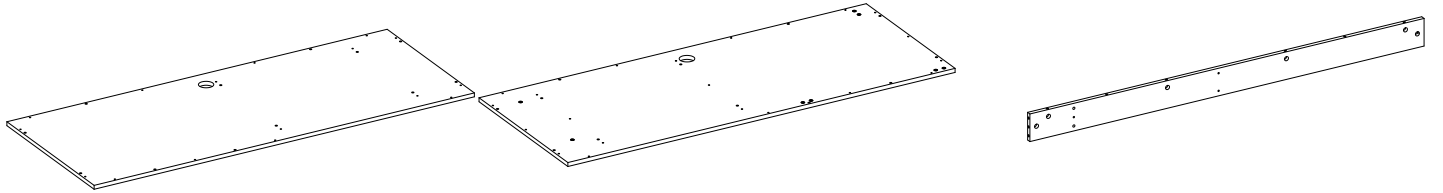

A- Panel superior del escritorio (Cant. 1)

B- Panel inferior del escritorio (Cant. 1)

C- Panel posterior del escritorio (Cant. 1)

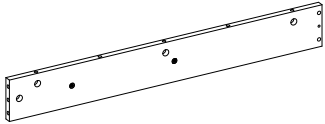

D- Panel derecho frontal del escritorio (Cant. 1)

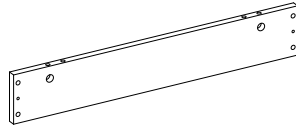

E- Panel lateral del escritorio (Cant. 3)

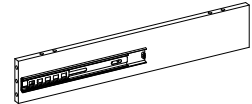

F- Panel divisor izquierdo (Cant. 2)

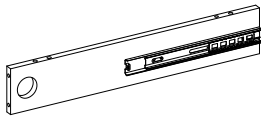

G- Panel divisor derecho del escritorio (Cant. 1)

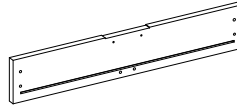

H1- Frente del cajón (Cant. 2)

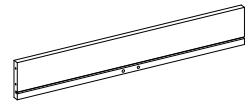

H2- Panel posterior del cajón (Cant. 2)

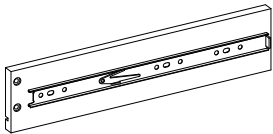

H3- Lado izquierdo del cajón (Cant. 2)

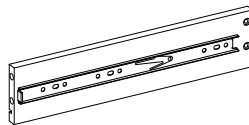

H4- Lado derecho del cajón (Cant. 2)

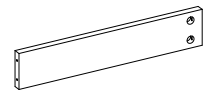

H5- Soporte inferior del cajón (Cant. 2)

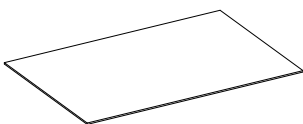

H6- Panel inferior del cajón (Cant. 2)

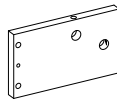

I- Panel izquierdo frontal del escritorio (Cant. 1)

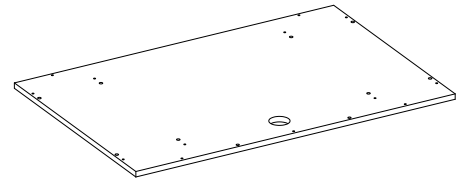

J- Panel superior del retorno (Cant. 1)

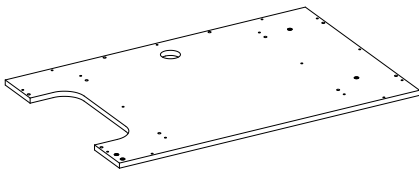

K- Panel inferior del retorno (Cant. 1)

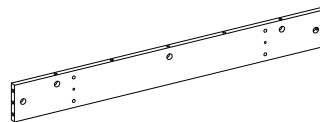

L- Panel posterior del retorno (Cant. 1)

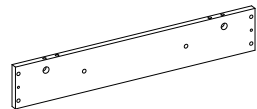

M- Lado izq. del retorno (Cant. 1)

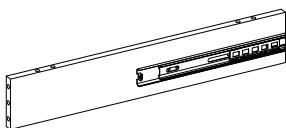

N- Panel divisor der. del retorno (Cant. 1)

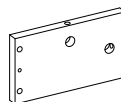

O- Frente izq. del retorno (Cant. 1)

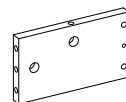

P- Frente der. del retorno (Cant. 1)

Lista de partes y material de ferretería

Por favor lea completamente las instrucciones y verifique que estén todas las partes antes de iniciar el ensamblado.

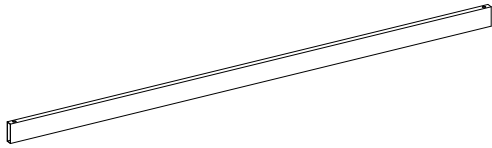

Q- Soporte largo del escritorio (Cant. 1)

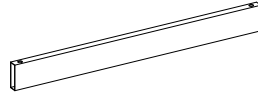

R- Soporte corto del escritorio (Cant. 1)

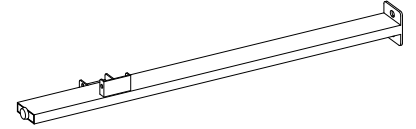

S- Pata posterior del escritorio (Cant. 1)

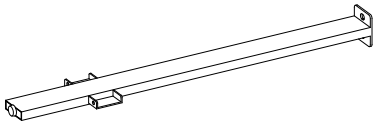

T- Pata frontal del escritorio (Cant. 1)

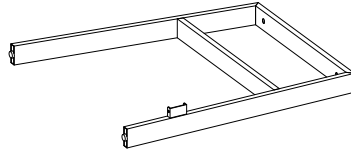

U- Marco lateral del escritorio (Cant. 1)

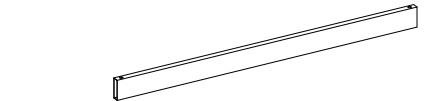

V- Soporte del retorno (Cant. 1)

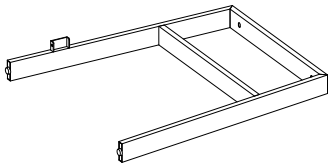

W- Marco lateral del retorno (Cant. 1)



X- Guía de cable (Cant. 3)

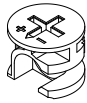

(1) Tuerca de fijación grande
(Cant. 46+2 extra)

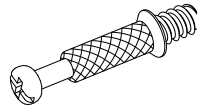

(2) Perno de fijación grande
(Cant. 46+2 extra)

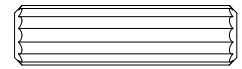

(3) Clavija de madera de M8 x 30 mm
(Cant. 74+2 extra)

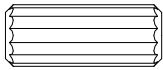

(4) Clavija de madera de M8 x 20 mm
(Cant. 2+1 extra)

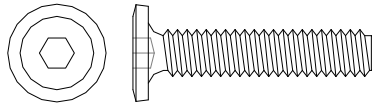

(5) Perno de 1/4" x 30 mm
(Cant. 6+1 extra)



(6) Arandela de presión
(Cant. 14+1 extra)

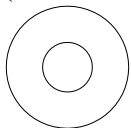

(7) Arandela plana
(Cant. 14+1 extra)

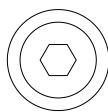

(8) Perno de 1/4" x 18 mm
(Cant. 14+1 extra)

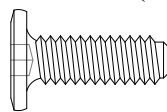

(9) Perno de 5/32" x 12 mm
(Cant. 6+1 extra)

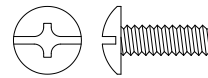

(10) Tuerca de fijación pequeña
(Cant. 12+1 extra)



(11) Perno de fijación pequeño
(Cant. 12+1 extra)



(12) Perno de M4 x 35 mm
(Cant. 48+2 extra)

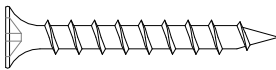

(13) Perno de cabeza plana de M4 x 14 mm
(Cant. 4+1 extra)

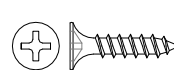

(14) Manija
(Cant. 2)



(15) Ojal (Cant. 2)

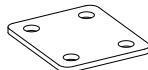

(16) Soporte de metal (Cant. 1)



Llave hexagonal (Cant. 1)

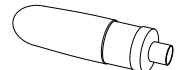

Pegamento (Cant. 2)

Herramientas requeridas: Llave hexagonal (proveida), desarmador estrella y mazo (no proveidos).

Ensamble del cajón

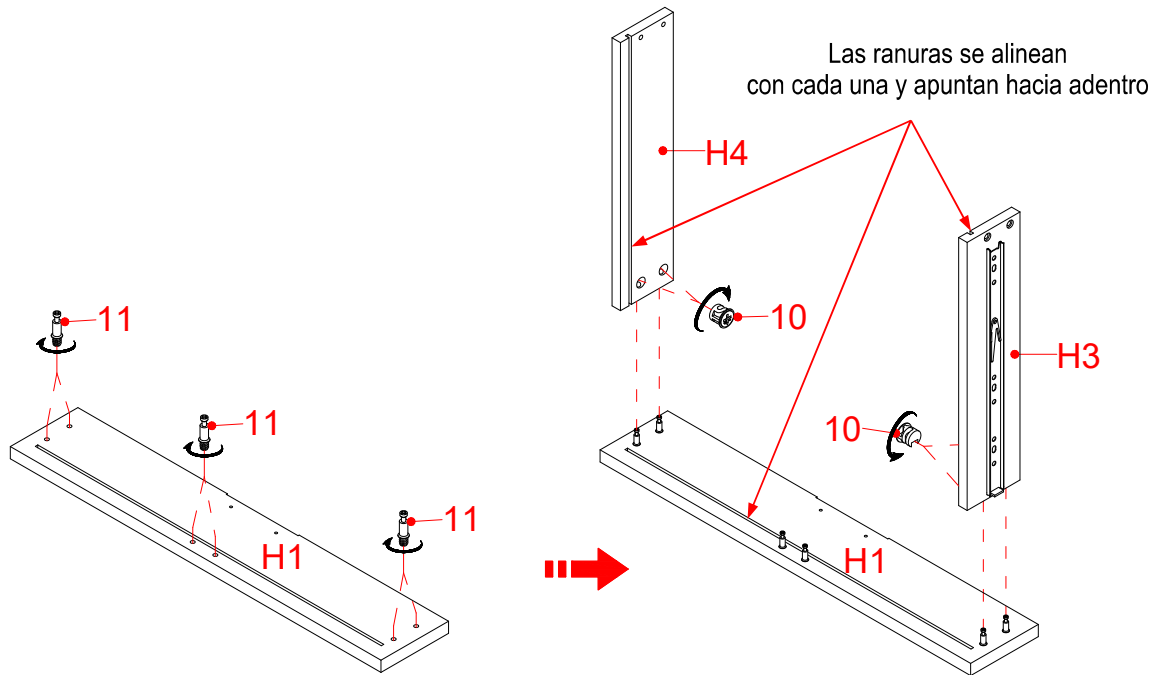

1. Desempacar la unidad y confirmar que se tiene todo el material de ferretería y partes requeridas. Ensamblar la unidad en un piso alfombrado o en el cartón vacío para evitar rasguños.
2. Atornillar los pernos de fijación pequeños (11) en los agujeros pequeños designados en el frente del cajón (H1) usando el desarmador estrella.
3. Sujetar el lado izquierdo y derecho del cajón (H3 y H4) al frente del cajón (H1) con 4 tuercas de fijación pequeñas (10).

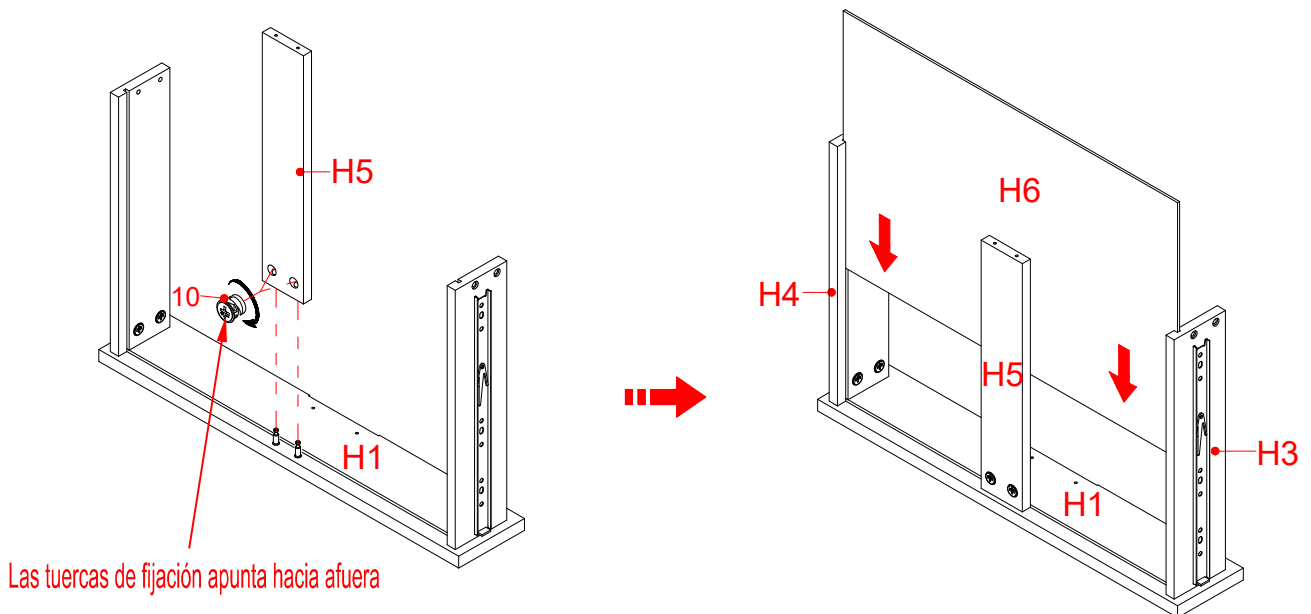

4. Sujetar el soporte inferior del cajón (H5) al frente del cajón (H1) con 2 tuercas de fijación pequeñas (10).
5. Deslizar el panel inferior del cajón (H6) todo el camino hacia las ranuras.

Ensamble del cajón

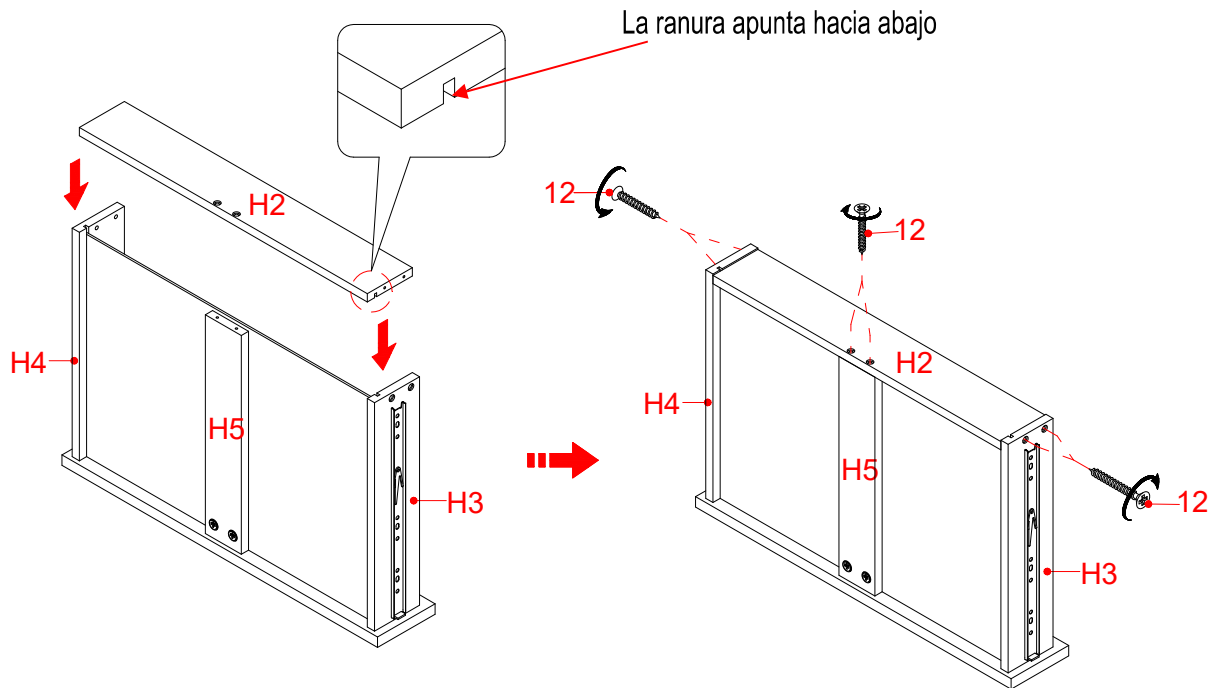

6. Sujetar el panel posterior del cajón (H2) a los paneles laterales del cajón (H3 y H4) y el soporte inferior (H5) con 6 pernos de 35 mm (12). Asegurar que el panel inferior del cajón (H6) encaje en la ranura del panel posterior del cajón (H2).

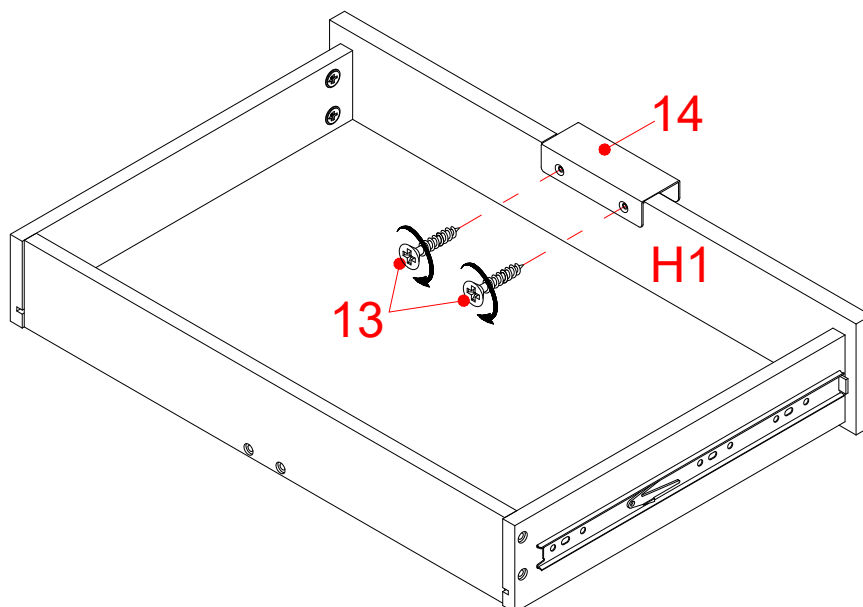

7. Poner el cajón ensamblado en posición vertical. Adjuntar la manija (14) a los agujeros pilotos en el frente del cajón (H1) con 2 pernos de cabeza plana de 14 mm (13).
8. Repetir el mismo procedimiento para ensamblar el otro cajón.

Ensamble del escritorio

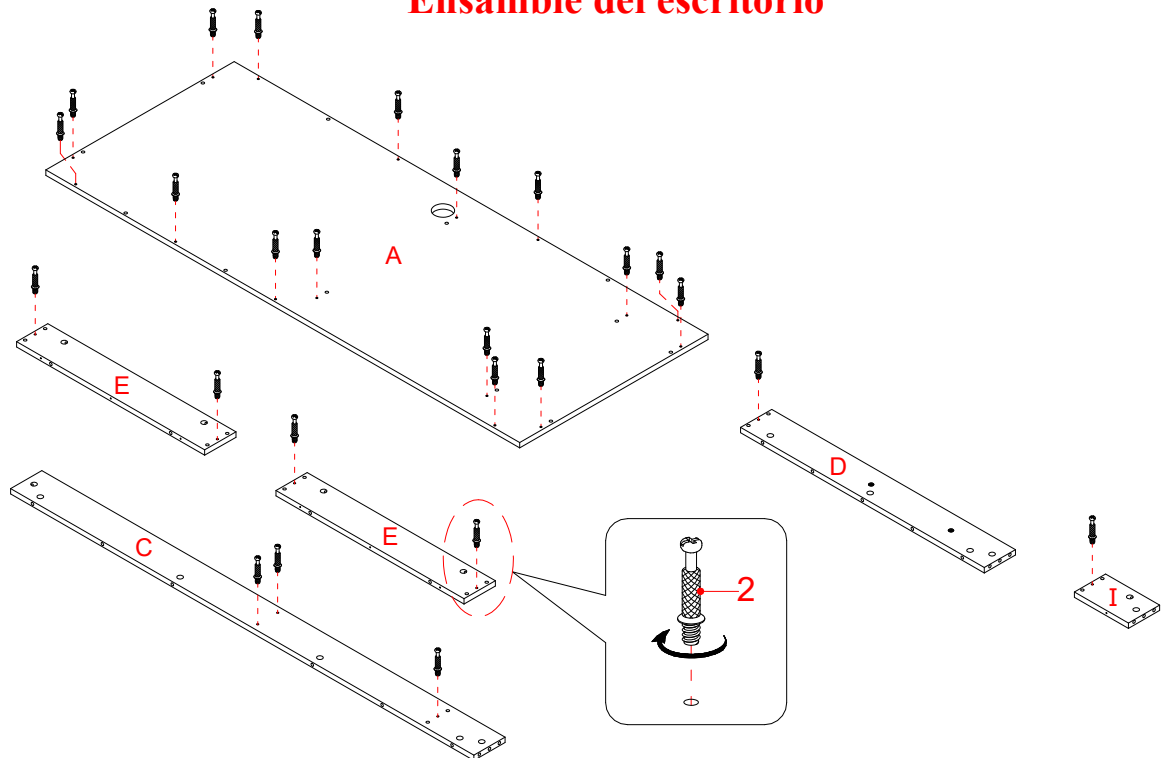

9. Atornillar los pernos de fijación grandes (2) en los agujeros pequeños designados en el panel superior del cajón (A), en el panel posterior (C), en los paneles laterales (E) y en los paneles frontales (D y I) usando el desarmador estrella.

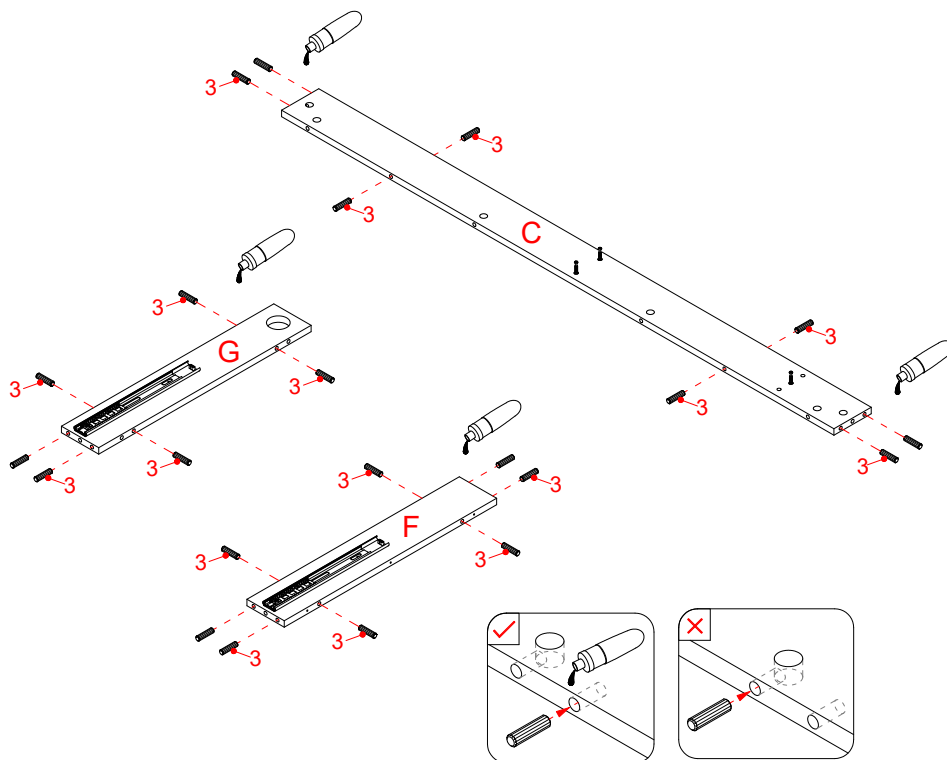

10. Pegar las clavijas de madera de M8 x 30 mm (3) en los agujeros interiores del panel posterior (C) y en los paneles divisores (F y G).

NOTA: Usar una cantidad pequeña de pegamento en ambos lados de las clavijas.

Ensamble del escritorio

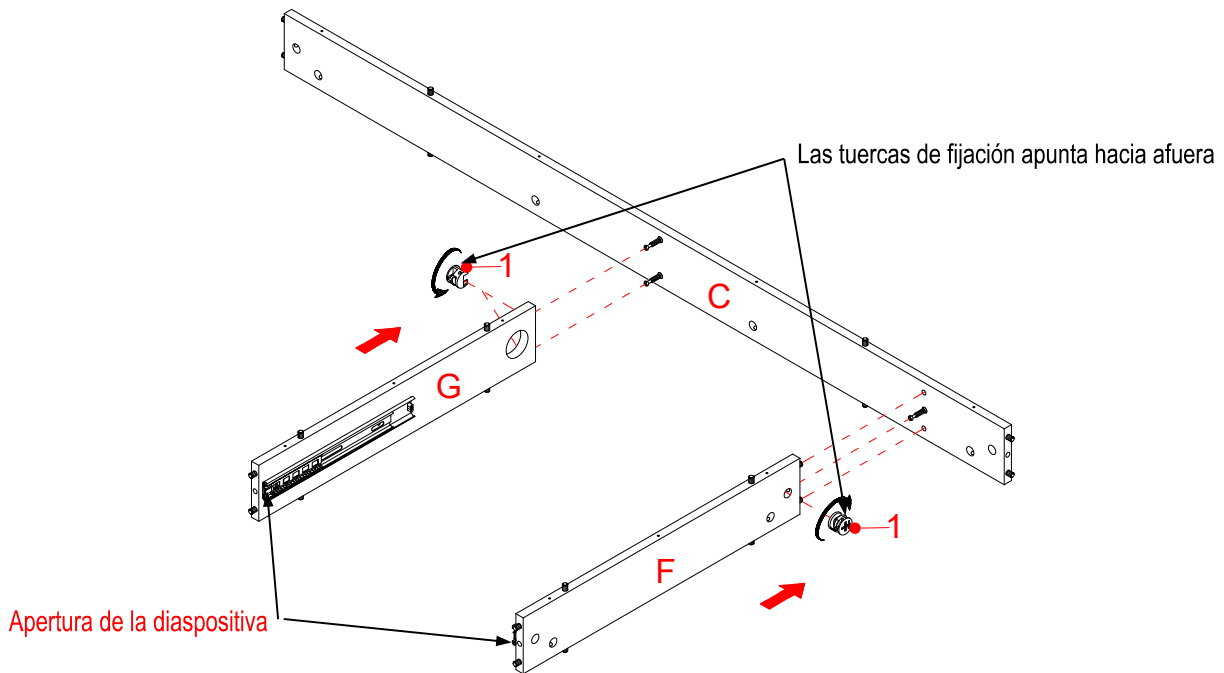

11. Alinear y adjuntar los paneles divisores (F y G) al panel posterior (C) empleando 3 tuercas de fijación grandes (1) (Consulte la página 3 del sistema de tuerca de fijación).

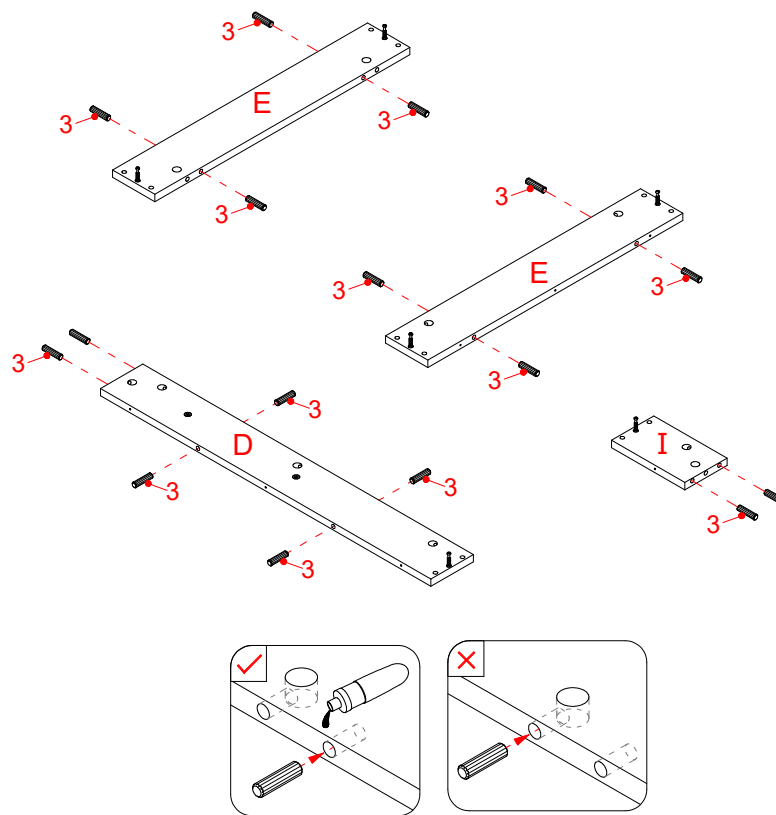

12. Pegar las clavijas de madera de M8 x 30 mm (3) en los agujeros internos de los paneles laterales (E) y en los paneles frontales (D y I).

Ensamble del escritorio

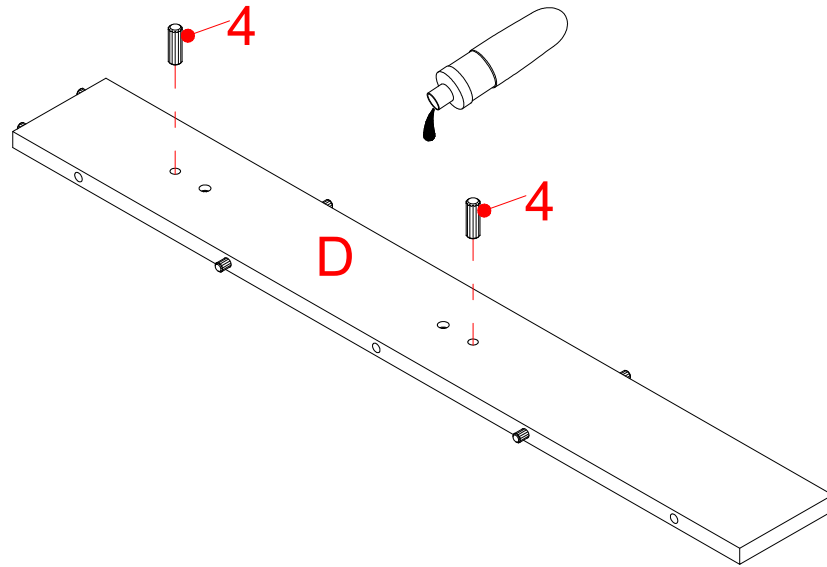

13. Pegar las clavijas de madera de M8 x 20 mm (4) en los agujeros internos del panel derecho frontal del escritorio (D).

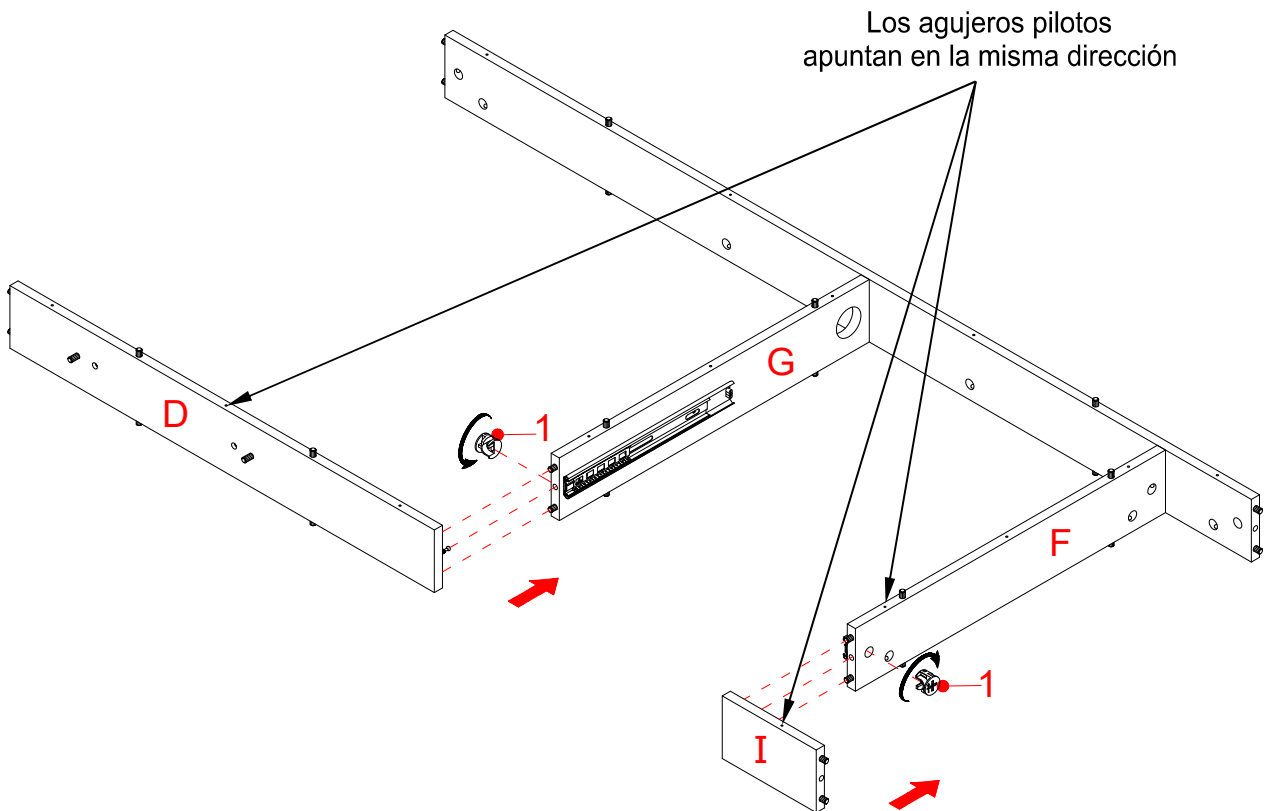

14. Adjuntar el panel derecho frontal del escritorio (D) al panel divisor derecho (G) con una tuerca de fijación grande (1).
15. Adjuntar el panel izquierdo frontal del escritorio (I) al panel divisor izquierdo (F) con una tuerca de fijación grande (1).

Ensamble del escritorio

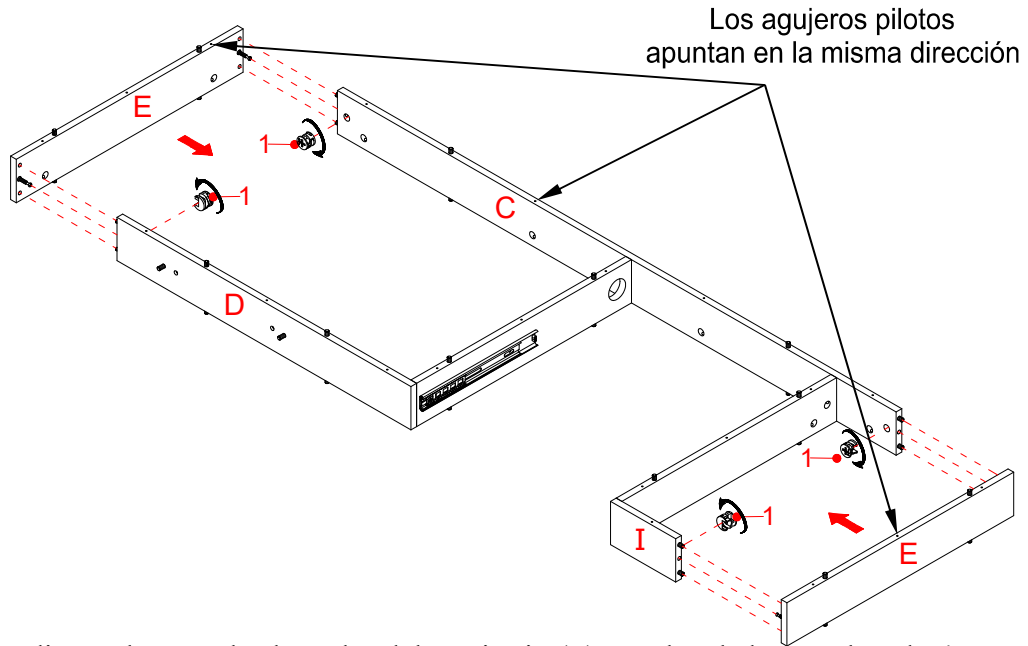

16. Alinear y adjuntar los paneles laterales del escritorio (E) a ambos lados empleando 4 tuercas de fijación grandes (1).

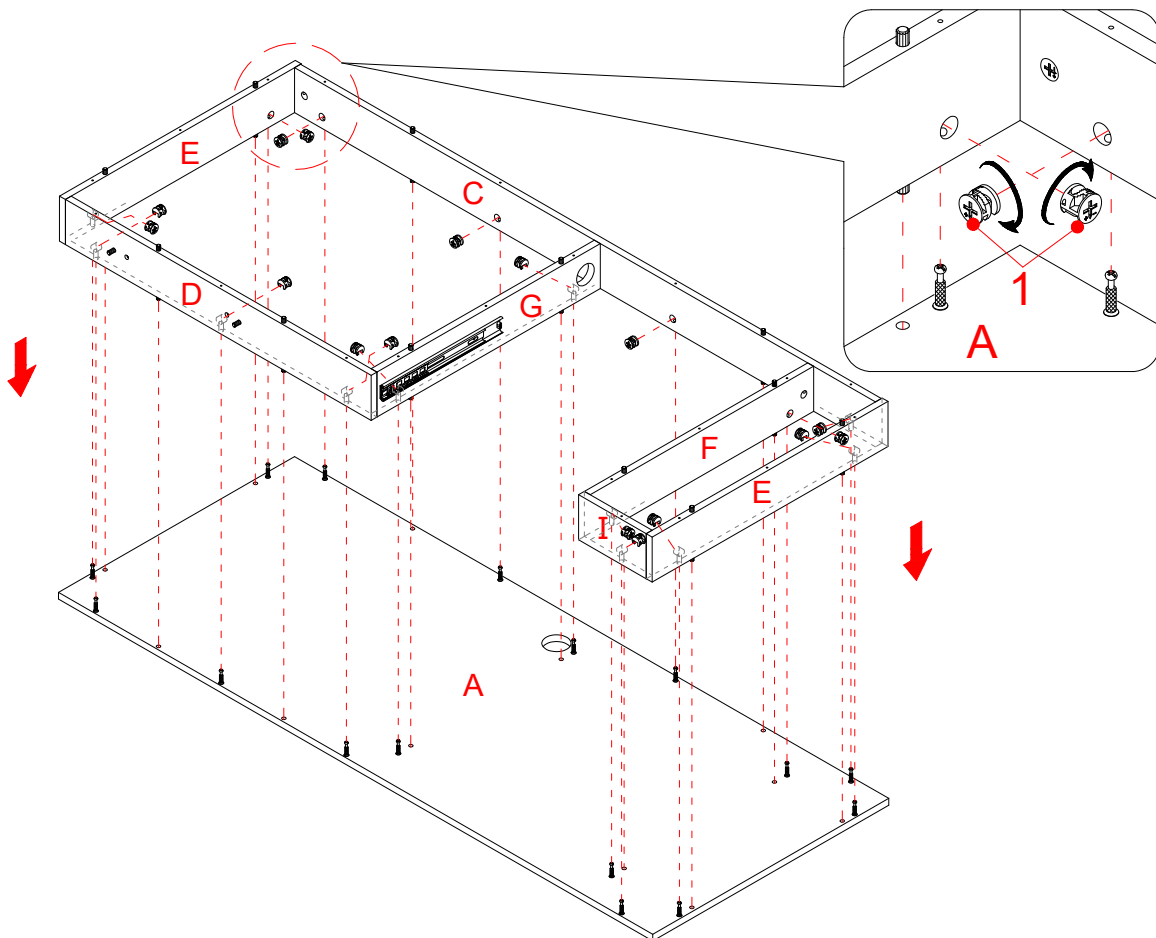

17. Alinear y adjuntar el ensamble previo al panel superior del escritorio (A) empleando 16 tuercas de fijación grandes (1).

Ensamble del escritorio

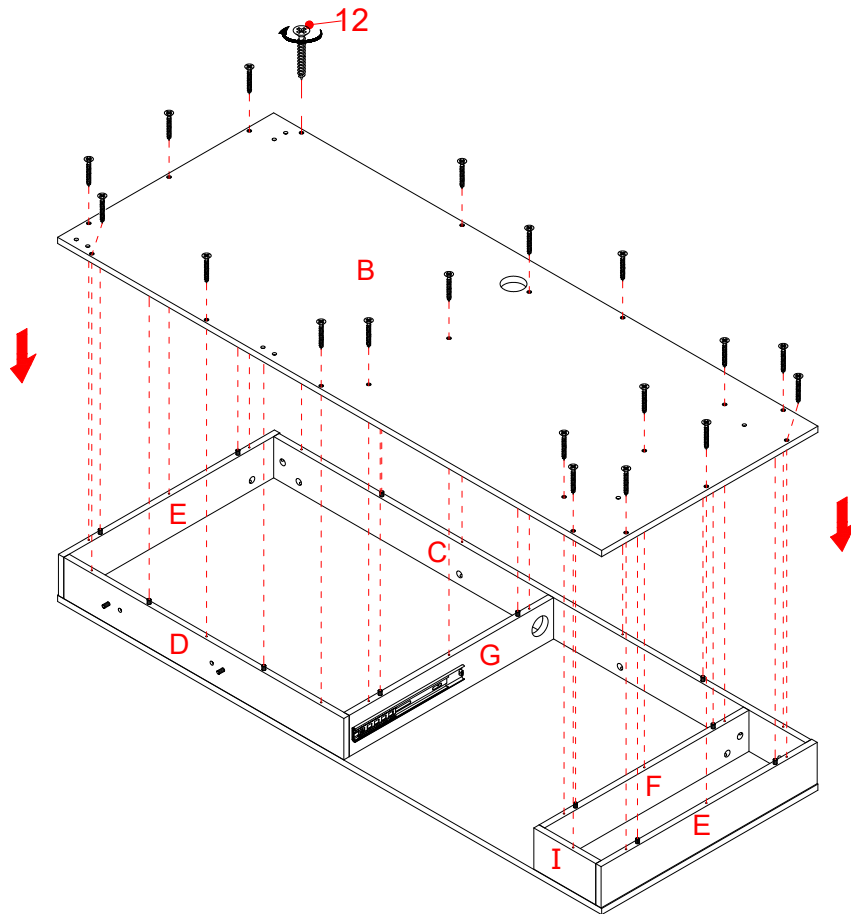

18. Adjuntar el panel inferior del escritorio (B) al ensamble previo con pernos de 35 mm (12).

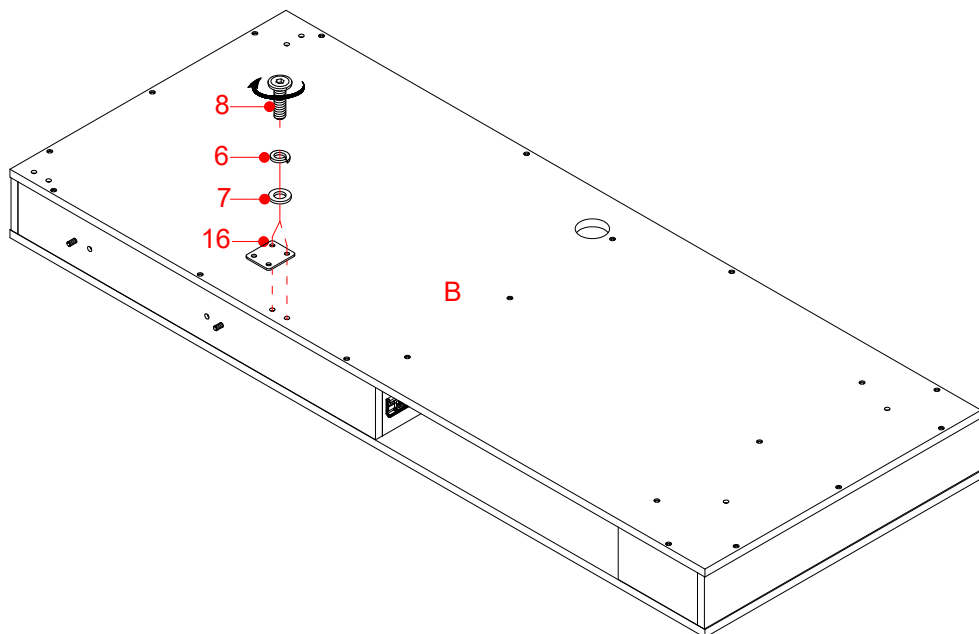

19. Adjuntar el soporte de metal (16) al panel inferior del escritorio (B) con 2 pernos de 18 mm (8) y 2 arandelas (6 y 7).

Ensamble del escritorio

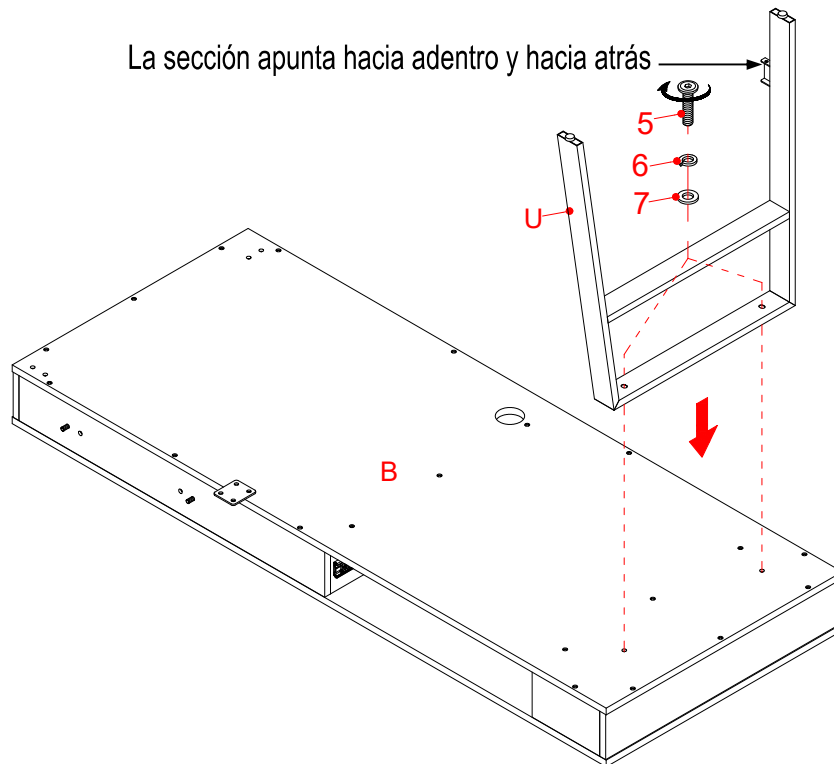

20. Adjuntar el marco lateral del escritorio (U) al panel inferior (B) con 2 pernos de 30 mm (5) y 2 arandelas (6 y 7).

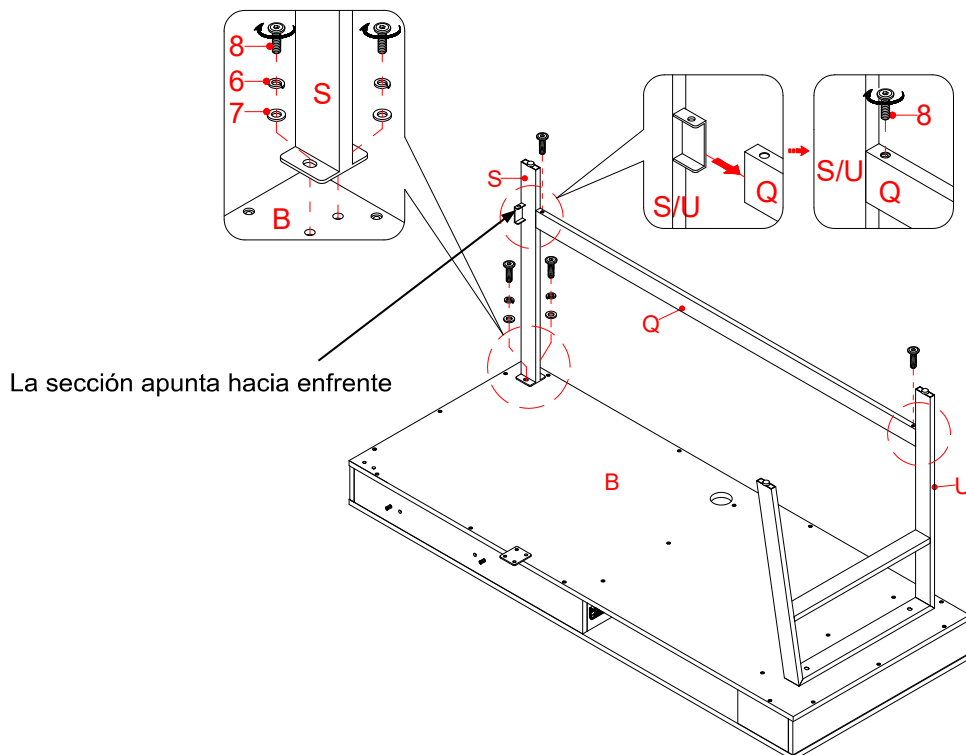

21. Adjuntar el soporte largo del escritorio (Q) entre el marco lateral del escritorio (U) y la pata posterior del escritorio (S) con 2 pernos de 18 mm (8).
22. Sujetar la pata posterior del escritorio (S) al panel inferior del escritorio (B) con 2 pernos de 18 mm (8) y 2 arandelas (6 y 7).

Ensamble del escritorio

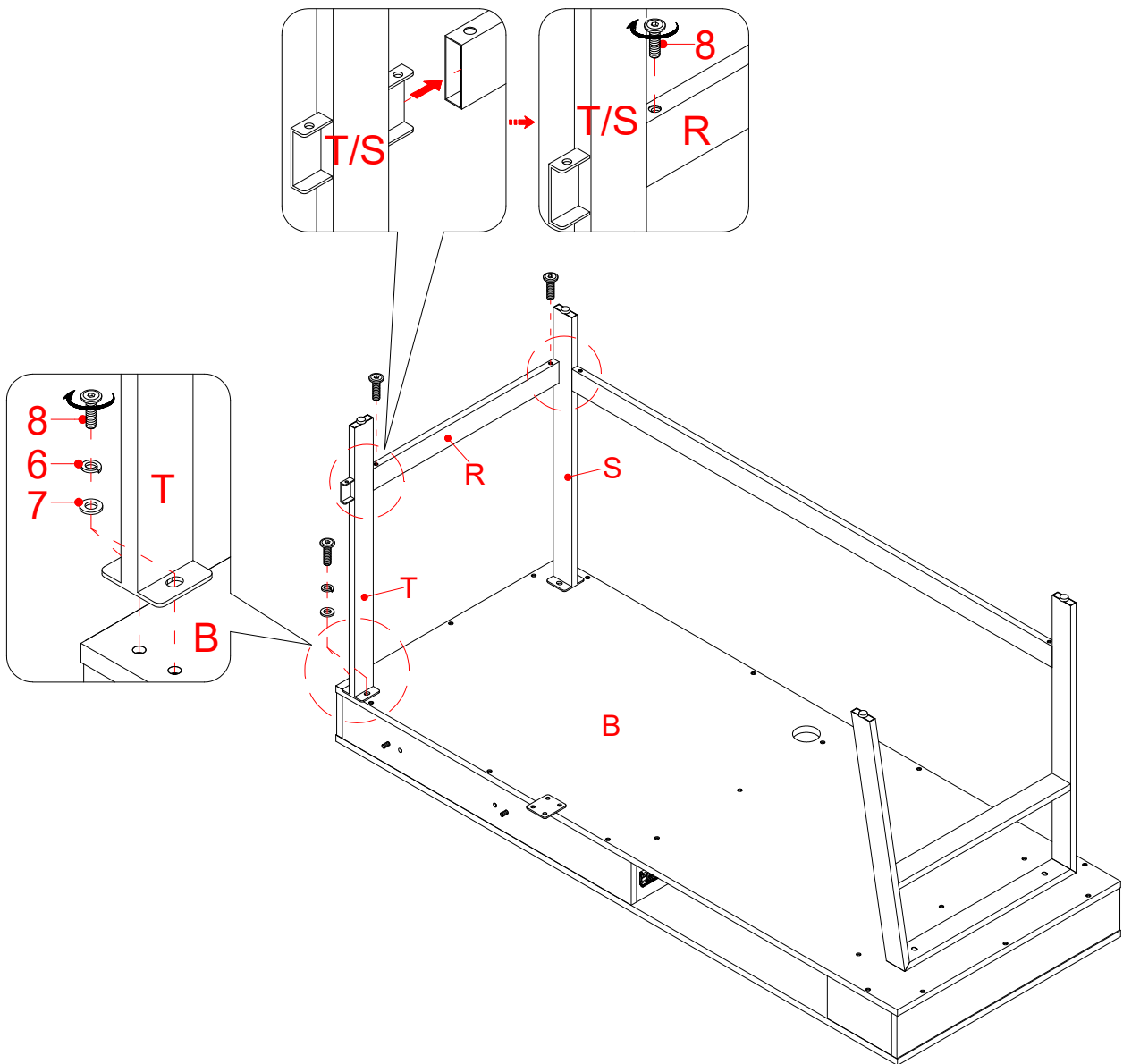

23. Adjuntar el soporte corto del escritorio (R) entre las patas posterior y frontal del escritorio (T y S) con 2 pernos de 18 mm (8).
24. Sujetar la pata frontal del escritorio (T) al panel inferior del escritorio (B) con 2 pernos de 18 mm (8) y 2 arandelas (6 y 7).

Ensamble del retorno

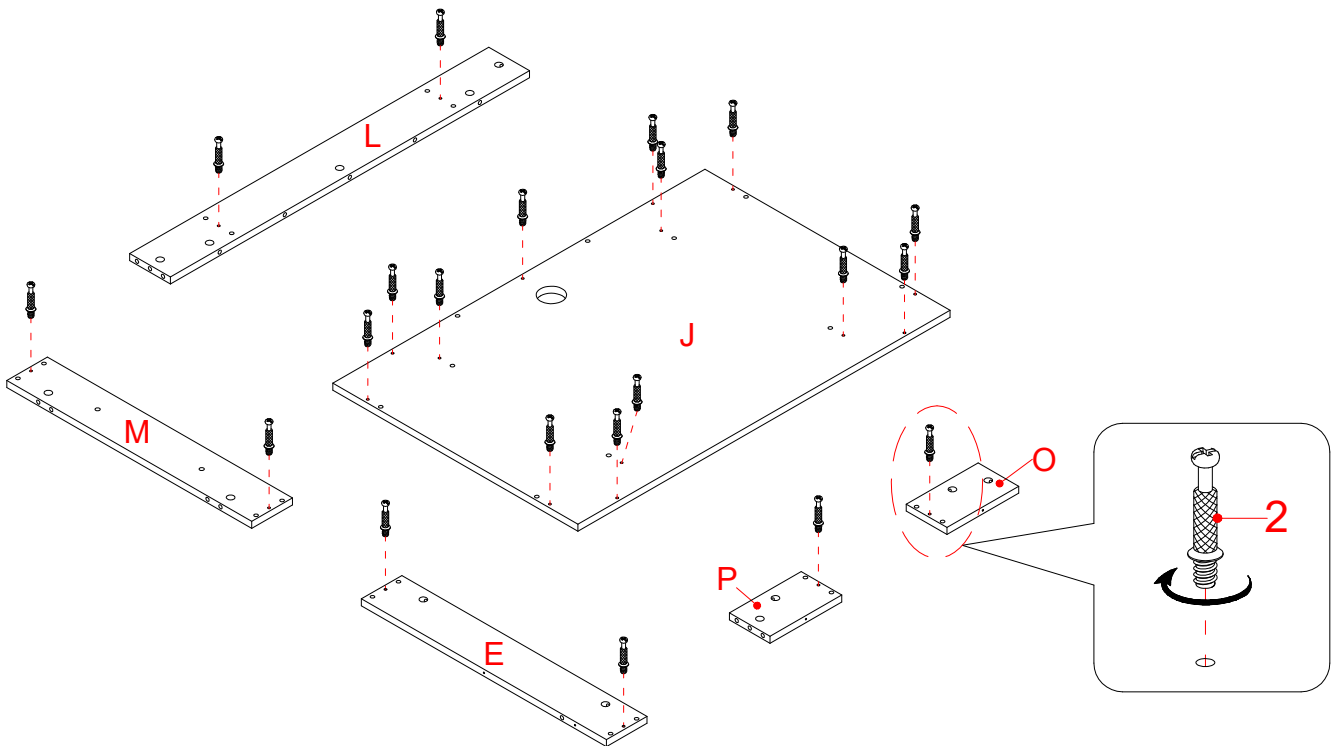

25. Atornillar los pernos de fijación grandes (2) en los agujeros chicos designados en el panel superior del retorno (J), en el panel posterior (L), en el panel izquierdo del retorno (M), en el panel lateral del escritorio (E) y en los paneles frontales (O y P) usando el desarmador estrella.

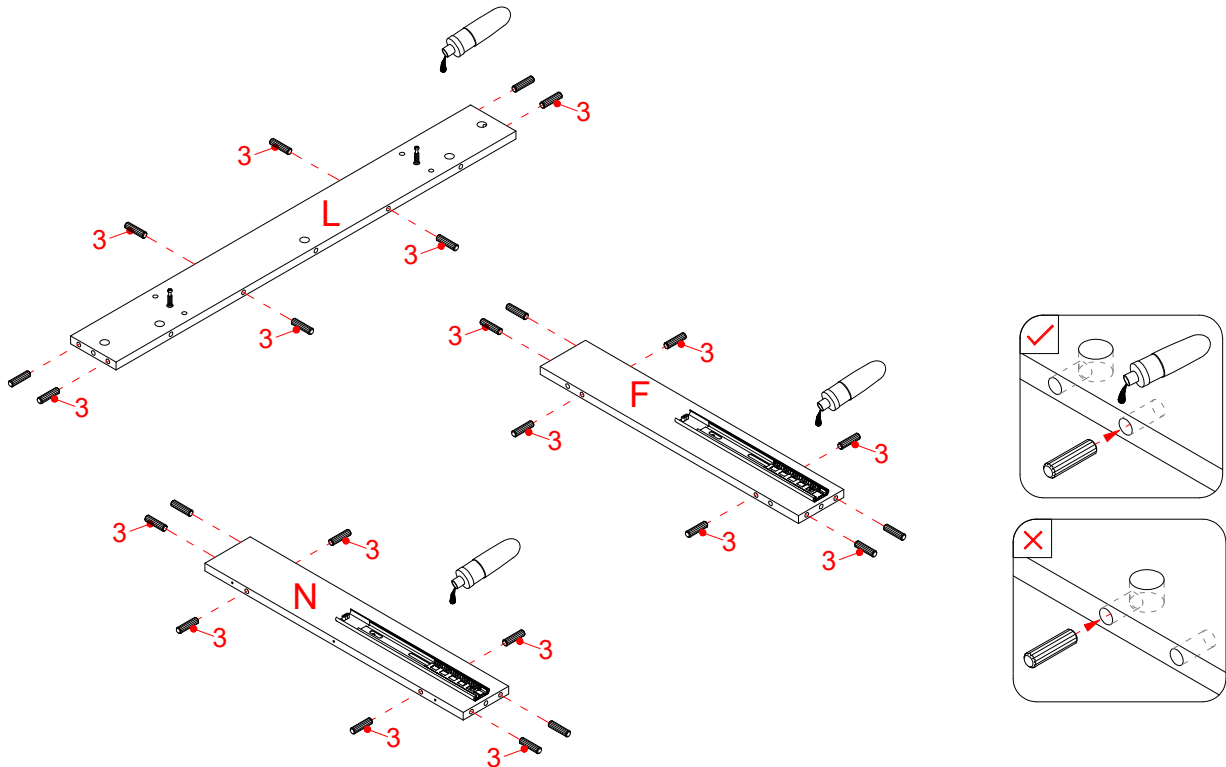

26. Pegar la clavija de madera de M8 x 30 mm (3) en los agujeros internos del panel posterior (L) y de los paneles divisores (F y N). **NOTA:** Usar una cantidad pequeña de pegamento en ambos lados de las clavijas.

Ensamble del retorno

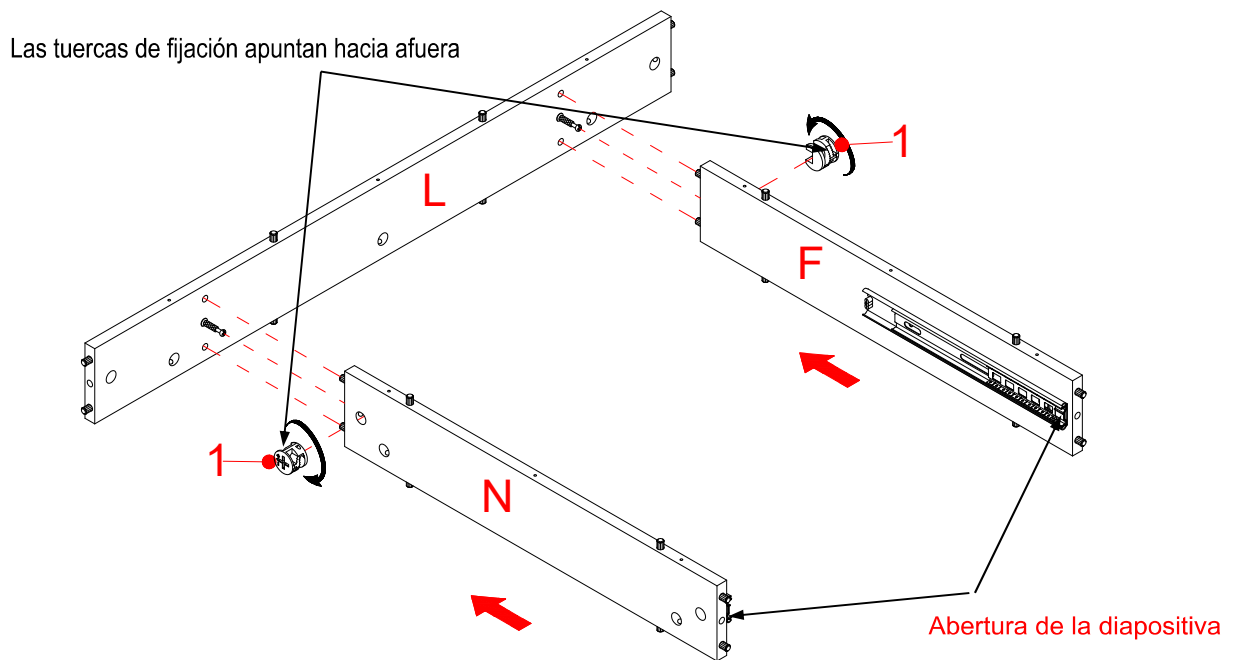

27. Alinear y adjuntar los paneles divisores (F y N) al panel posterior (L) empleando 2 tuercas de fijación grandes (1) (Consulte la página 3 del sistema de tuercas de fijación).

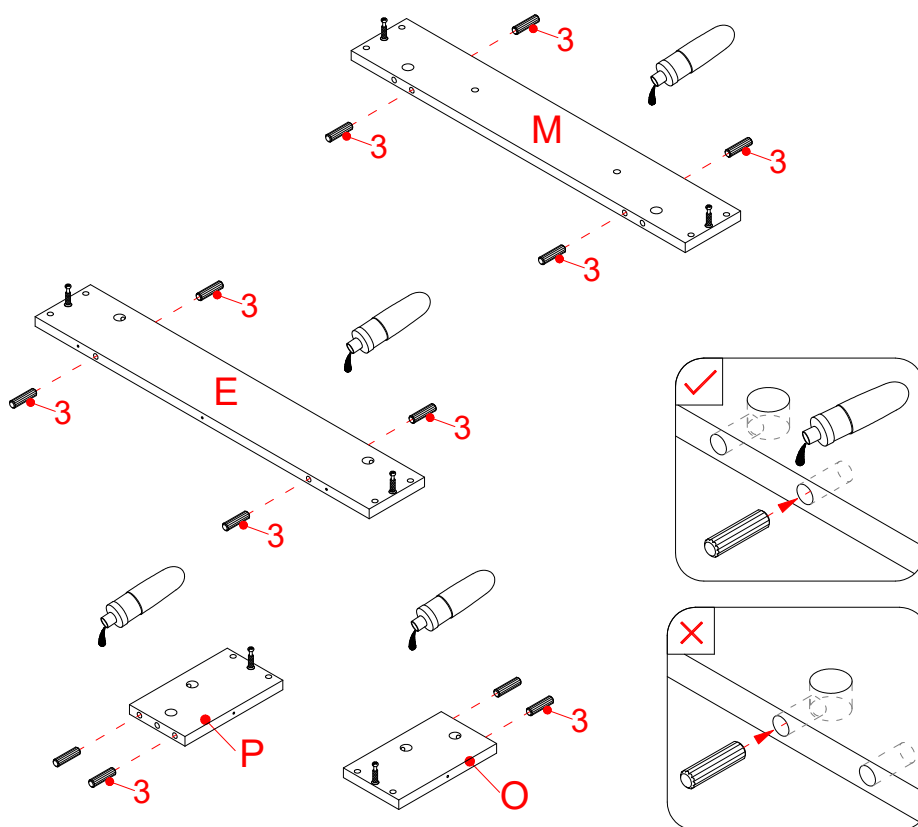

28. Pegar las clavijas de madera de M8 x 30 mm (3) en los agujeros internos de los paneles laterales (E y M) y de los paneles frontales (O y P).

Ensamble del retorno

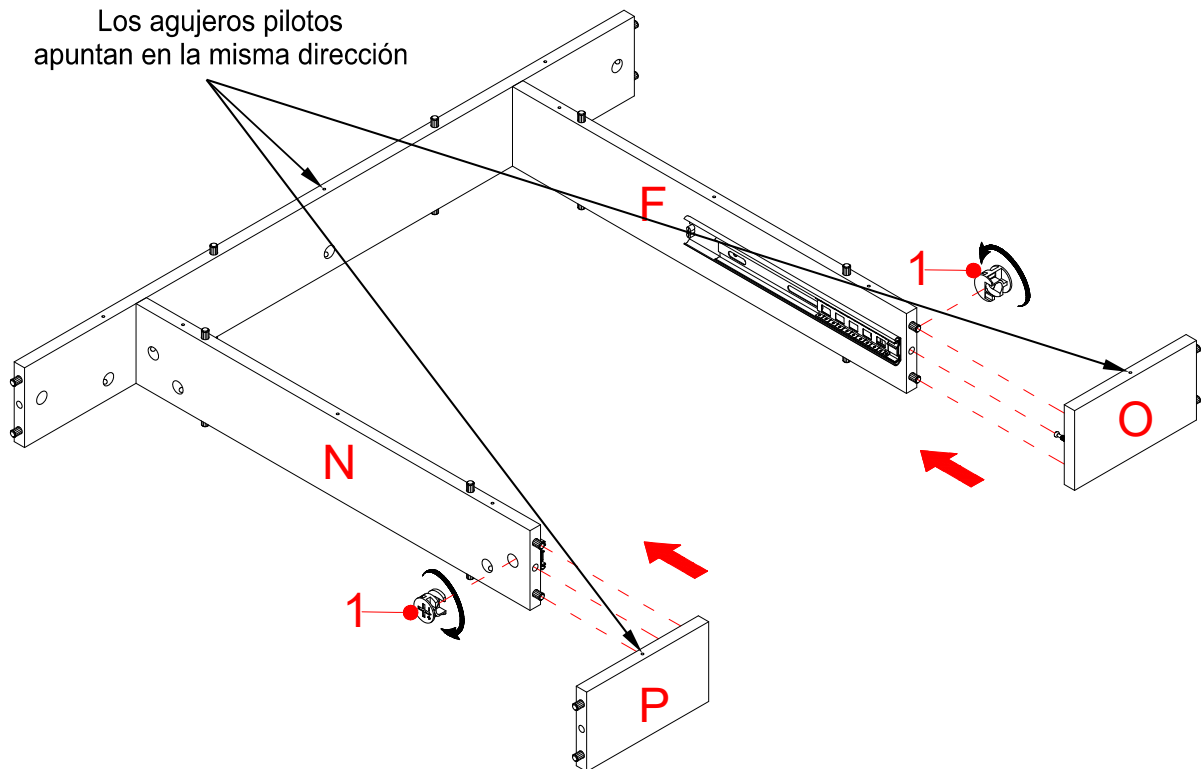

29. Adjuntar el panel derecho frontal del retorno (P) al panel divisor derecho (N) con una tuerca de fijación grande (1).
30. Adjuntar el panel izquierdo frontal del retorno (O) al panel divisor izquierdo (F) con una tuerca de fijación grande (1).

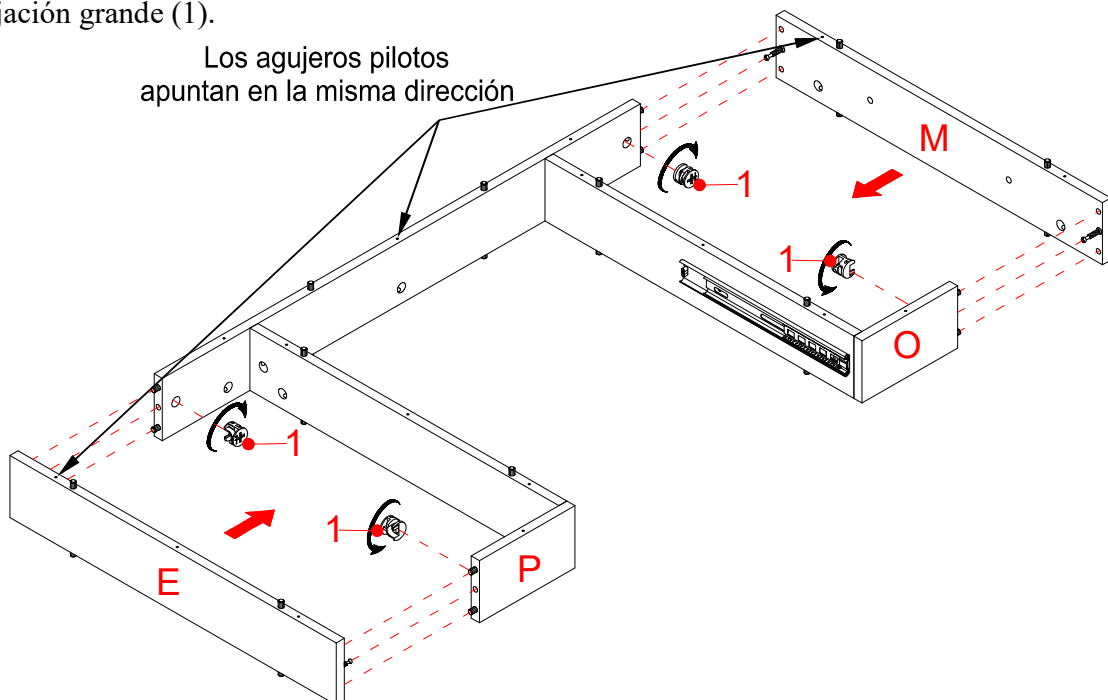

31. Adjuntar el panel lateral del escritorio (E) al panel frontal derecho del retorno (P) y el panel posterior (L) empleando 2 tuercas de fijación grandes (1).
32. Adjuntar el lado izquierdo del retorno (M) al panel izquierdo frontal del retorno (O) y el panel posterior (L) empleando 2 tuercas de fijación grandes (1).

Ensamble del retorno

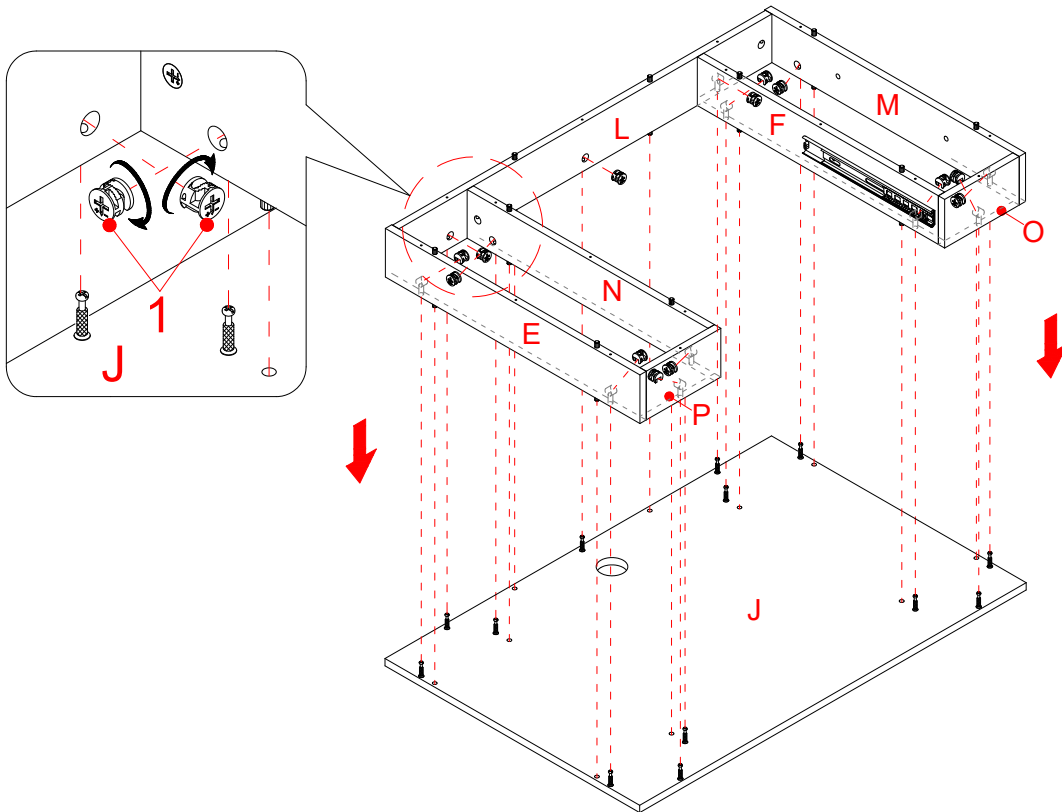

33. Alinear y adjuntar el ensamble previo al panel superior del retorno (J) empleando 13 tuercas de fijación grandes (1).

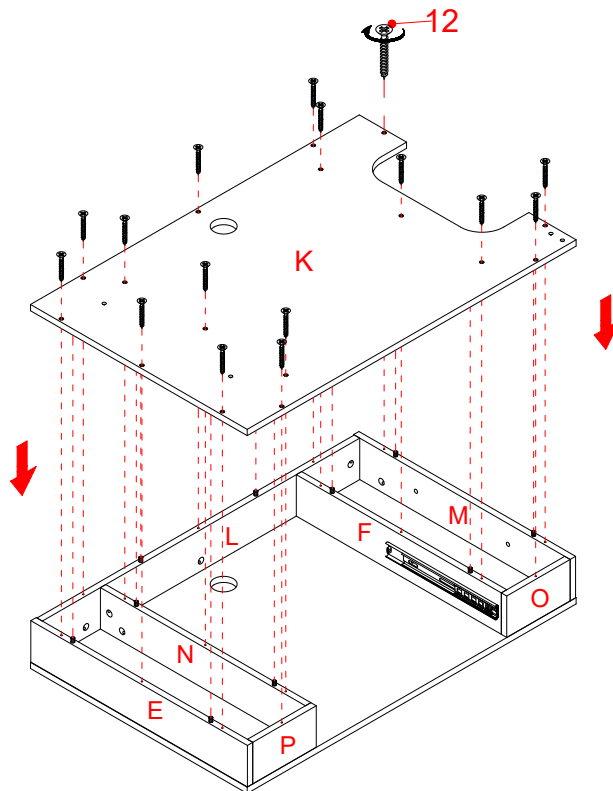

34. Adjuntar el panel inferior del retorno (K) al ensamble previo con los pernos de 35 mm (12).

Ensamble del retorno

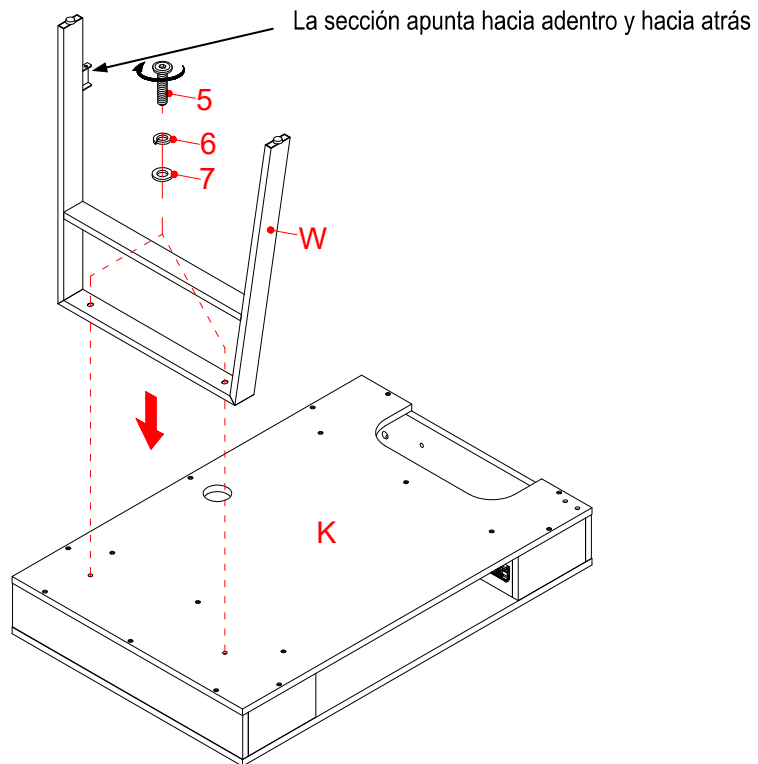

35. Adjuntar el marco lateral del retorno (W) al panel inferior (K) con 2 pernos de 30 mm (5) y 2 arandelas (6 y 7).

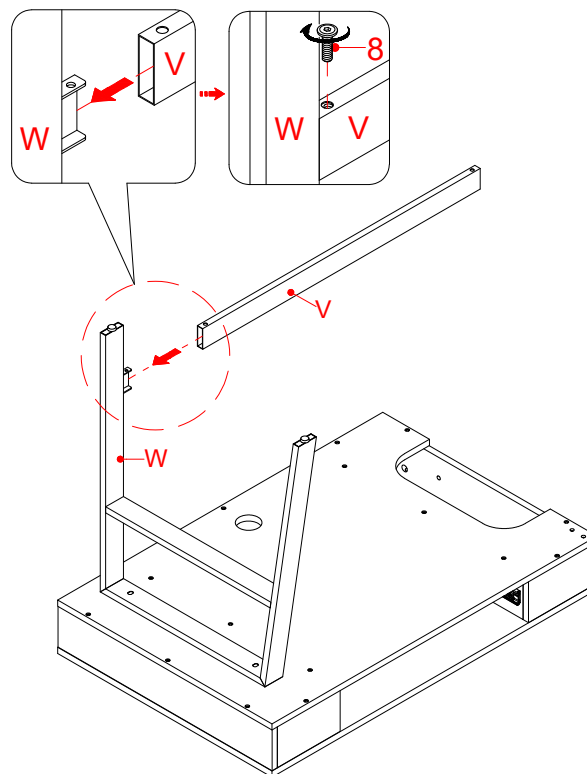

36. Adjuntar del soporte del retorno (V) al marco lateral (W) con un perno de 18 mm (8).

Instructivo de ensamble

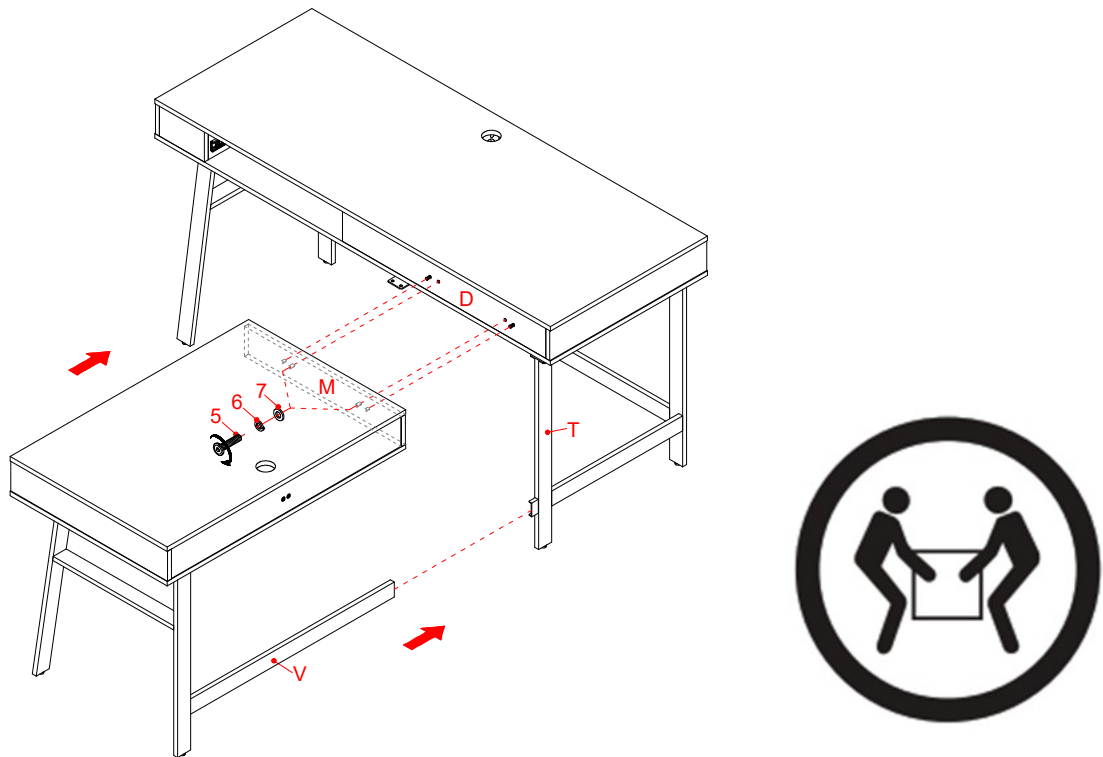

37. Pedir asistencia para poner los escritorios ensamblados en posición vertical y poner cerca del lugar final.
38. Alinear y adjuntar el retorno ensamblado al escritorio con 2 pernos de 30 mm (5) y 2 arandelas (6 y 7).
39. Adjuntar el soporte del retorno (V) a la pata frontal del escritorio (T).

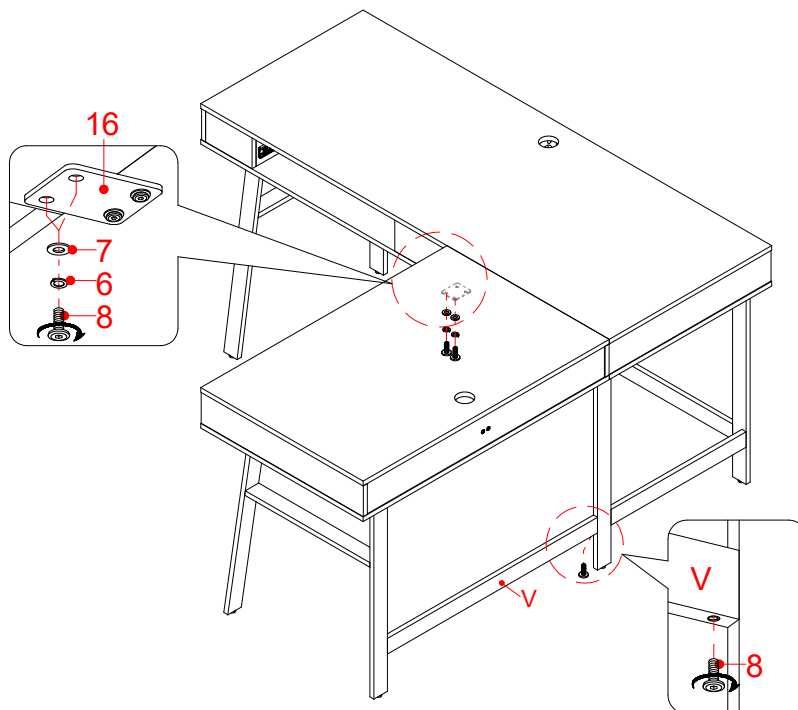

40. Asegurar el soporte de metal (16) al panel inferior del retorno (K) con 2 pernos de 18 mm (8) y 2 arandelas (6 y 7).
41. Adjuntar el soporte del retorno (V) a la pata frontal del escritorio (T) con un perno de 18 mm (8).

Instructivo de ensamble

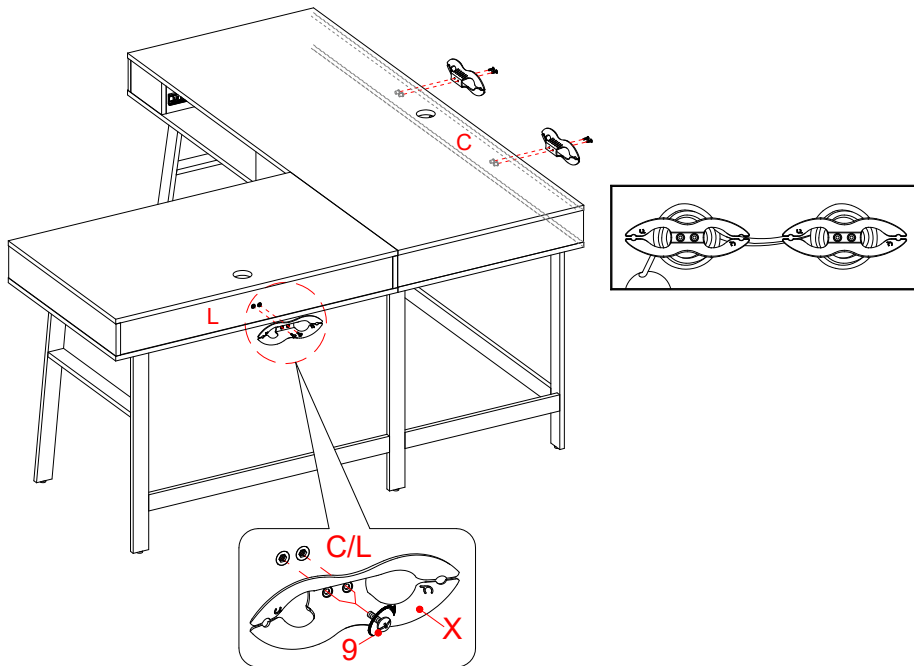

42. Adjuntar 2 guías de cable (X) a los paneles posteriores (C y L) con los pernos de 12 mm (9).

NOTA: Usted puede usar las guías de cables para mantener los cables de su centro de entretenimiento organizados.

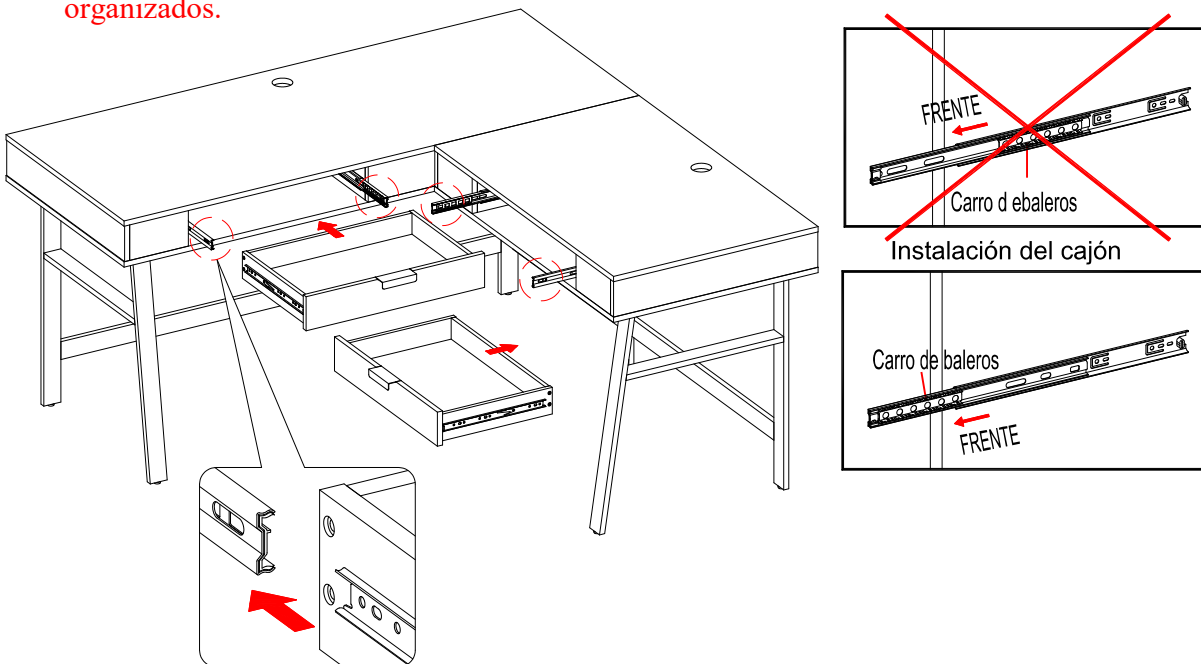

43. Insertar los cajones ensamblados en el marco. Para insertar los cajones ensamblados en la unidad, Extender los carriles de la corredera de baleros en los paneles divisores (F, G y N) todo el camino hacia enfrente (incluyendo el carrito de baleros). Luego alinear los retornos de corredera en el cajón ensamblado con los carriles de corredera y empujar el cajón hacia adentro hasta que tope.

NOTA: Si el cajón no se mueve suavemente, por favor saque y repita el paso. Si necesita sacar el cajón, por favor jale el cajón todo el camino, y empuje simultáneamente las palancas de liberación de plástico de las correderas de baleros hacia arriba en una y hacia abajo en la otra, después jalé el cajón completamente afuera.

Instructivo de ensamble

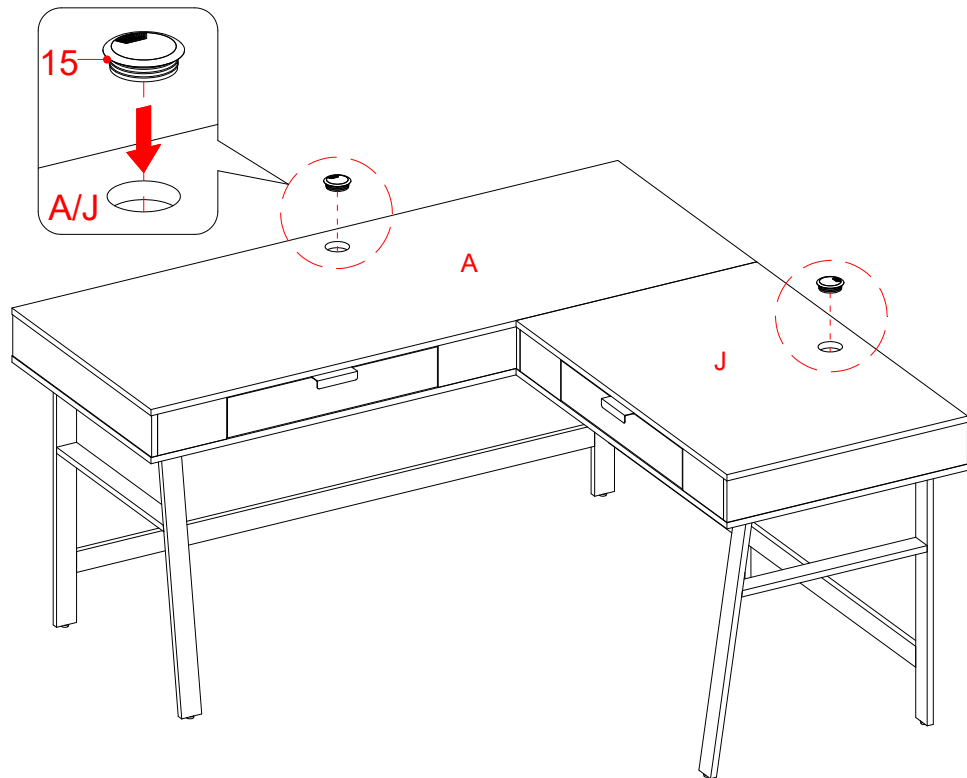

44. Insertar los ojales (15) para esconder los agujeros de los paneles superiores (A y J).

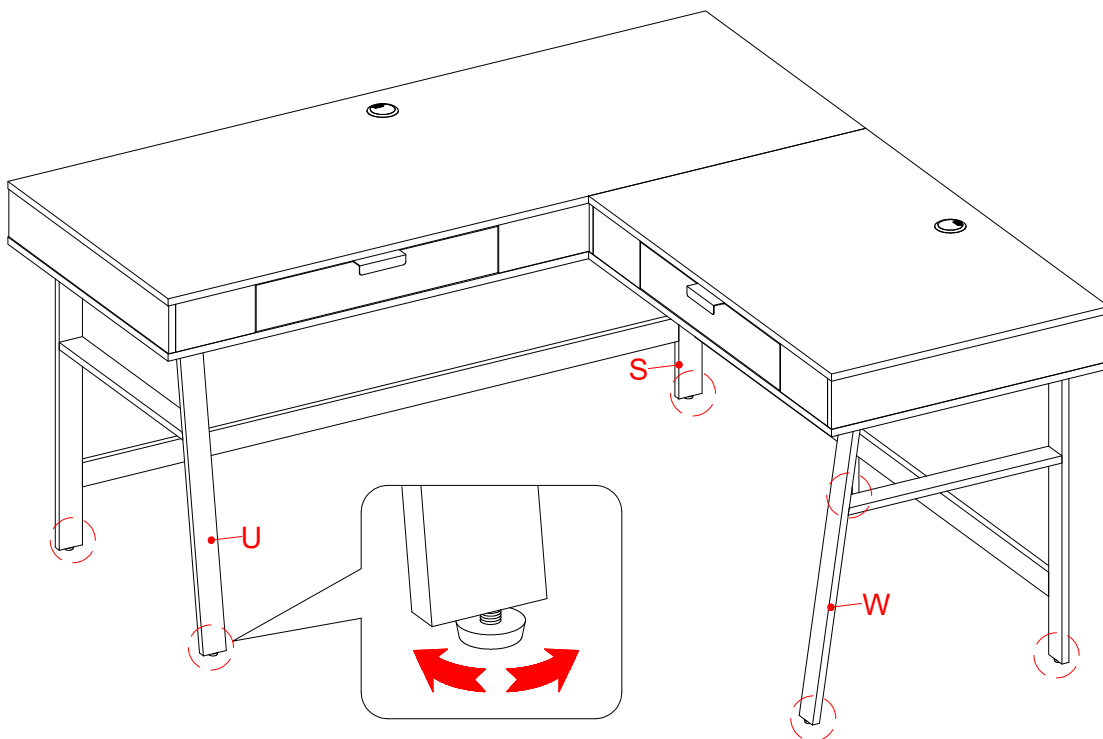

45. Si fuera necesario, ajustar los niveladores de piso pre-adjuntados a la parte inferior de ambas patas para nivelar la unidad.

Mantenimiento y Cuidados

- Use una toalla suave y limpia para evitar daños y rayaduras.
- Uso de cera para pulir muebles no es necesario. Si desea usar cera, pruébela en un área que no sea visible para revisar su funcionamiento.
- Usar solventes de cualquier tipo puede dañar el acabado del mueble.
- Nunca use agua para limpiar la unidad, ya que le puede dañar el acabado.
- Siempre utilice protección para vasos cuando los ponga sobre la unidad.
- Líquidos derramados deben limpiarse inmediatamente, con una toalla suave evitando tallar.
- Siempre utilizar protectores en caso de poner cosas calientes. El calor puede provocar una reacción química en el acabado y dañarlo.
- En caso que su unidad sea manchada durante el uso le recomendamos hablar a un profesional para que le ayude.
- Revisar los tornillos periódicamente y apretar en caso necesario.

Más recomendaciones para el cuidado de su mueble

Es mejor mantener la unidad en una área de clima controlado. Temperatura extrema y cambios de humedad pueden causar cambios como partes pandas, molduras que se contraigan o que la madera se raje. Es recomendable mantener la unidad lejos del sol directo ya que puede dañar el acabado.

Cuidados adecuados y limpieza pueden extender la vida útil de su unidad. Siga estas recomendaciones y mantendrá su mueble en buenas condiciones de uso por muchos años.

Esperamos que disfrute su mueble por muchos años.
Gracias por su compra!

GARANTÍA DE CALIDAD

Nosotros estamos seguros que usted se encontrará feliz con la compra de este producto de Whalen Furniture.

Si este producto tiene algún defecto de ensamble o material, o si tiene alguna falla en uso normal, nosotros lo repararemos o lo re-emplazaremos hasta por un año a partir de la fecha de compra. Todo producto de Whalen Furniture es diseñado para alcanzar sus expectativas más altas. Nosotros le garantizamos que inmediatamente podrá ver el valor de nuestra mercancía de la más alta calidad.

Esta garantía le proporciona derechos legales específicos y tal vez tenga otros derechos que varían de estado a estado ó de provincia en provincia.

Servicio al cliente: 1-866-942-5362
Hora Estandar del Pacífico: 8:30 a.m. - 4:30 p.m., de Lunes a Viernes
www.whalenfurniture.com

